

CF₃I Gas Mixtures: Breakdown Characteristics and Potential for Electrical Insulation

L. Chen, P. Widger, M. S. Kamarudin, H. Griffiths, and A. Haddad

Abstract—SF₆ is a potent greenhouse gas, and there has been research into more environmentally friendly alternative gases with the aim of replacing the use of SF₆ gas in high-voltage equipment. So far, the research into alternative gases has shown that CF₃I gas mixtures have promising dielectric properties comparable to those of SF₆. This paper provides an overview of research into CF₃I gas and its mixtures, and gives an insight into its key properties. These include laboratory tests on the gas mixtures and initial applications to electrical power equipment. The insulation capability makes CF₃I a feasible alternative to SF₆ as an insulation medium where arc quenching is not required. On the other hand, iodine deposition after electrical discharge means CF₃I may not be a suitable arc quenching gas for switchgear applications that require high current interruption unless a solution is found for controlled capture of the iodine.

Index Terms—Electric breakdown, flashover, gas insulation, sulphur hexafluoride (SF₆) and trifluoroiodomethane (CF₃I).

I. INTRODUCTION

SF₆ is an electronegative gas and its dielectric strength is three times higher than that of air [1]. The outstanding properties of SF₆ have resulted in its extensive use as the gas medium in high-voltage equipment such as gas-insulated switchgear (GIS) and gas-insulated lines (GIL). However, there is environmental concerns related to SF₆ gas. Alternative insulation gases to replace SF₆ have been investigated in recent decades and an emerging candidate is trifluoroiodomethane (CF₃I) gas. The weak chemical bond C-I in CF₃I means that it can be decomposed quickly in the atmosphere and, therefore, the ozone depletion potential [2] for surface release and the global warming potential [3] of CF₃I are extremely low. In this way, CF₃I is considered to be an environmentally friendly alternative to SF₆. However, the boiling point of CF₃I at atmospheric pressure is -22.5 °C [4], which would liquefy under typical operating pressure of high-voltage GIS/GIL equipment. Therefore, it has to be used in low proportions as part of a binary mixture with CO₂ or N₂ to reduce the liquefaction temperature. When considering CF₃I as an

alternative to SF₆, it is important to take into account that switchgear operated on the medium-voltage (11 kV) network uses SF₆ slightly above atmospheric pressure. For this reason, CF₃I could be considered as a potential replacement candidate for application in medium-voltage switchgear.

This paper provides an overview of the research work into the gas properties that has been conducted on CF₃I at Cardiff University. Therefore, for completeness it recalls some of the main results that were published earlier and presents more recent research results. In the paper, we describe the experimental investigations carried out on CF₃I gas mixtures including: a) a comparison of properties between SF₆ and CF₃I; b) breakdown results obtained on rod-plane and plane-plane configurations filled with CF₃I/CO₂ gas mixtures; c) a reduced scale coaxial test system to explore dielectric properties of using CF₃I gas mixtures for application in GIL; and d) laboratory results of industrial switchgear designed for SF₆ gas when the gas is replaced with CF₃I/CO₂ gas mixture.

II. COMPARISON OF PROPERTIES OF SF₆ AND CF₃I GASES AND THEIR MIXTURES

SF₆ and CF₃I have a number of similar properties: both gases are colourless, odourless and nonflammable. Since CF₃I has to be used as a mixture, an appropriate CF₃I gas mixture can be chosen based on numerous properties which are discussed further in this section:

A. Environmental Impacts

The environmental impact is generally based on two parameters: global warming potential (GWP) and ozone depletion potential (ODP).

GWP is a relative measure to CO₂ of the heat absorption capability of a greenhouse gas in the atmosphere. It can be seen from Table I [3] that SF₆ has a very high GWP and a long atmospheric lifetime, making it an undesirable gas medium with a high environmental impact. In comparison, CF₃I has a much lower GWP value and can be considered as an

This work was supported through PhD studentships from the Engineering and Physical Sciences Research Council (EPSRC), Transformation of the Top and Tail of Energy Networks Grant [grant number EP/I031707/1] and the Power Networks Research Academy (PNRA).

“Information about the data supporting the results in this article, including how to access them, can be found in the Cardiff University data catalogue at <http://dx.doi.org/10.17035/d.2016.0008395739>”.

L. Chen, P. Widger, H. Griffiths and A. Haddad are with the School of Engineering at Cardiff University, Cardiff, CF24 3AA, UK (e-mail: chent3@cf.ac.uk; widgerp@cf.ac.uk; griffithsh@cf.ac.uk; haddad@cf.ac.uk).

M. S. Kamarudin is with Universiti Tun Hussein Onn Malaysia, Batu Pahat, Johor, 86400, Malaysia (e-mail: saufi@uthm.edu.my).

Digital Object Identifier

environmentally friendly alternative.

The ODP is the degradation that can be caused to the ozone layer by a greenhouse gas. The C-I bond in CF₃I dissociates due to the absorption of sunlight and, once the released iodine reaches the lower troposphere, it will be removed through rainout. Previous studies have reported ODP values of <0.008 for CF₃I, which represents an extremely low impact [5].

TABLE I
Global warming potential (GWP) for CO₂, SF₆ and CF₃I [3].

Chemical Formula	Lifetime (years)	GWP for a Given Time Horizon (years)			
		SAR (100) ¹	20	100	500
CO ₂	–	1	1	1	1
SF ₆	3200	23900	15100	22200	32400
CF ₃ I	0.005	–	1	1	<1

¹SAR: second assessment report on climate change by IPCC

B. Liquefaction Conditions of CF₃I Gas Mixtures

The boiling temperature or the saturation vapour pressure of pure CF₃I gas was measured by Duan et al. [4], and an analytical correlation (1) was derived from the experimental data for the vapour pressure calculation of CF₃I.

$$\ln(P/P_c) = (A_1\tau + A_2\tau^{1.25} + A_3\tau^3 + A_4\tau^7)T_c/T \quad (1)$$

The parameters of (1) were adopted from [4], and the boiling temperatures of SF₆, CF₃I and 20% and 30% CF₃I content for a pressure range up to 8 bar (abs.) are shown in Fig. 1. These curves were obtained with the assumption that the buffer gas behave as an ideal gas. As the pressure of a gas increases, the dielectric strength also increases. Based on operational experiences of gas-insulated systems, high reliability is found in the range of 4 to 8 bar for insulating gas pressures.

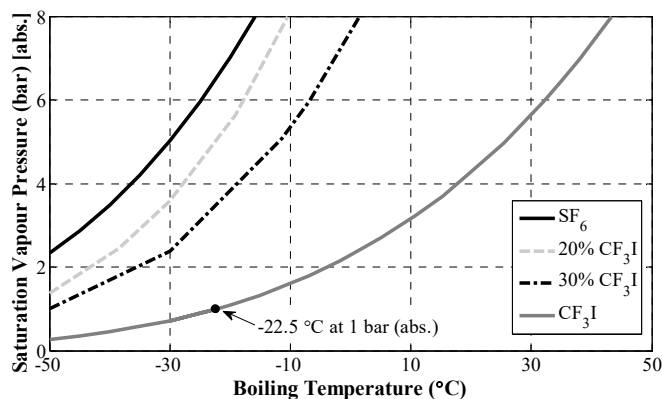

Fig. 1. Saturation vapour pressure vs. boiling temperature for SF₆, CF₃I and 20% and 30% CF₃I content.

C. Field Strength Analysis of CF₃I Gas and its Mixtures

The effective ionisation coefficients of different gases and gas mixtures were computed using BOLSIG+, which applies the two-term approximation of the Boltzmann equation [6]. Fig. 2 shows the pressure-normalised ionisation coefficient ($\alpha - \eta$) as a function of E/p.

The simulation provides an indication on the critical reduced field strength, $(E/p)_{crit}$ of various gases or gas mixtures. The simulated values for CF₃I and SF₆ at $(\alpha - \eta) = 0$ is consistent with experimental results reported in [7], which have shown that pure CF₃I has a dielectric strength around 1.2 times higher than that of SF₆. The steepness of the slope for CF₃I and SF₆ indicates that α is sensitive to changes in E/p. The insulation integrity of the gases is precarious near to the $(E/p)_{crit}$, since breakdown in SF₆ is known to happen very fast as a strong growth of ionisation would occur in the region where $E/p > (E/p)_{crit}$, especially in the presence of defects on the surface of gas-insulated equipment [1].

CF₃I gas mixtures show a less linear characteristic than pure CF₃I and SF₆ and are less sensitive to changes in E/p. The result for the 30/70% CF₃I gas mixtures were simulated using BOLSIG+ and are found to be in good agreement with the published results in the literature [8]. It was found that the $(E/p)_{crit}$ of the 30/70% CF₃I/N₂ gas mixture is higher than the $(E/p)_{crit}$ of the 30/70% CF₃I/CO₂ gas mixture, with 6.27 kV/mm/bar of 5.53 kV/mm/bar respectively.

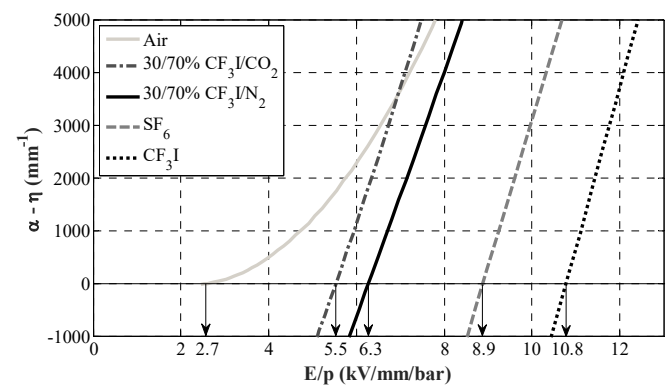

Fig. 2. Effective ionisation coefficients in pure gases (Air, SF₆ and CF₃I) and gas mixtures (30/70% CF₃I/N₂ and 30/70% CF₃I/CO₂). Arrows indicate the critical E/p at $(\alpha - \eta) = 0$.

D. By-products Analysis

It was reported in [9] that there is a build-up of by-products after a significant number of electrical discharges. For 25, 500, 1000 and 1300 electrical discharges, by-products analysis determined the generation of C₂F₆, C₂F₄, CHF₃, C₃F₈, C₃F₆ and C₃F₅I for CF₃I gas.

An experimental investigation was carried out by Katagiri et al. [10] on the density of by-products such as iodine and fluorine in CF₃I gas and its mixtures. It was reported that there is a much lower fluorine density measured for CF₃I than for SF₆. It is also encouraging to observe that nearly no fluorine content was detected for the 30/70% CF₃I/CO₂ gas mixture post current interruption. Due to the weak C-I bond, iodine is a likely source of by-product. The results reported in [10] show that a 30/70% CF₃I/CO₂ gas mixture produces only 1/3 of the iodine content in comparison to pure CF₃I gas when 400 A_{rms} was interrupted, which is almost proportional to the percentage of CF₃I as part of the mixture.

E. Toxicity Review of CF₃I

CF₃I is denser than air which means if substantial level of CF₃I is released and allowed to settle in an enclosed space, then it presents the risk of asphyxiation. The median lethal concentration (LC₅₀) of CF₃I was reported to be 27.4% performed on Sprague-Dawley rats [11], a value that would classify CF₃I as nontoxic. This is only an approximate value determined using two concentration levels (24 and 28.8%) for 15 min exposures, which makes the value questionable as LC₅₀ requires at least three concentrations and where the animals are exposed to a longer duration (4 to 6 hrs).

The US National Research Council's (NRC) committee on toxicology conducted an independent evaluation of the US Army's toxicity review for CF₃I. The investigation shows that the ability of CF₃I to induce mutagenesis is considered to be equivocal and may warrant further investigation. It was recommended that CF₃I has no observed adverse level (NOAEL) on cardiac sensitization if the concentration is 0.2%, whereas the lowest observed adverse level (LOAEL) is 0.4% [12]. However, it was also stated in the compressed gas association (CGA) standard that CF₃I is a nontoxic gas [13]. Since CF₃I is proposed only to be used in relatively low proportions as part of a gas mixture in high-voltage equipment, it is, therefore, suggested that the overall toxicity level of the CF₃I gas mixture would be drastically reduced when mixed with a buffer gas such as CO₂ or N₂.

III. LABORATORY TEST SETUP, EXPERIMENTAL TECHNIQUES AND FABRICATION OF TEST ELECTRODES

A. Lightning Impulse Test Setup

In high-voltage experiments, lightning impulse voltages are used to investigate the breakdown mechanisms. A standard lightning impulse voltage (1.2/50) reaches its peak voltage in 1.2 microseconds and then gradually declines, eventually reaching zero. The peak value of impulse voltages is measured by a digital oscilloscope (10 GS/s, 600 MHz), which is used to record the complete time characteristic of the voltage.

For the laboratory work, a 400 kV Haefely impulse generator was used for the generation of lightning impulse voltages (1.2/50) that led to gas discharges in either positive or negative impulse polarity for any chosen test electrode configuration. The circuit diagram for the impulse test set up can be seen in Fig. 3.

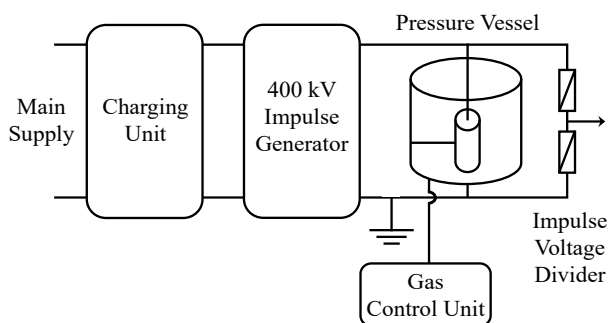

Fig. 3. Test circuit of lightning impulse experimental setup.

B. Experimental Techniques

The up-down standard test method was adopted for the breakdown tests [14]. This is a method that determines the 50% breakdown voltage U_{50} of an electrode configuration with a small number of discharges, which requires minimal experimental time and achieves a good level of accuracy. There is a minimum time interval of two minutes between each impulse shot, which allows the gas to recover its insulation strength after a breakdown event. Previous setup test results by the authors show a high level of repeatability, which indicates the time interval between impulses is sufficient. For every test arrangement, a minimum of 30 impulse voltage applications were applied.

For the test on the switchgear, all tests were conducted in accordance with standards BS60060-1 [14] and BS62271-1 [15] for high-voltage switchgear and controlgear.

C. Fabrication and Preparation of Test Electrodes

A rod-plane and plane-plane electrode configurations, as shown in Fig. 4, were chosen to represent a non-uniform and a uniform electric field distribution respectively. The rod electrode had a 45° angle and the tip had a radius of 0.5 mm and the plane electrodes had a diameter of 90 mm. Each conducting electrode had a M10 size inner thread for fitting onto the high-voltage bushing using an Ø10 mm rod. All the rod and plane electrodes were made of a brass alloy.

Prior to any testing, the electrodes were polished using a Struers Tegramin-25 machine. Polishing cloths and ultra-fine aluminium oxide polishing powder were used to achieve an efficient removal process and apply a smooth surface finish. This is to minimise the effect of surface roughness on the measured breakdown results. After breakdown test series, minor impulse impacts were observed on the surface of the plane electrode, the minor impact markings were useful to indicate the location of flashover in the centre of the contact.

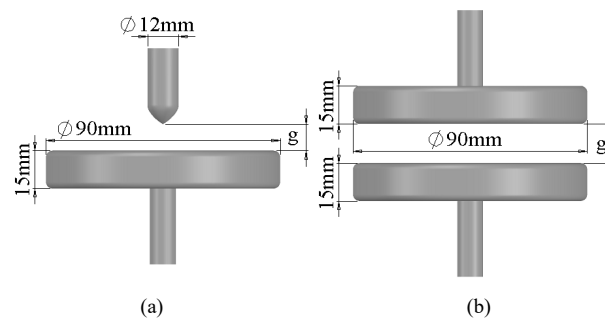

Fig. 4. (a) Rod-plane and (b) plane-plane electrode configurations.

IV. BREAKDOWN CHARACTERISTICS OF CF₃I GAS MIXTURES IN UNIFORM AND NON-UNIFORM GEOMETRIES

To characterise CF₃I gas mixtures as an insulation medium, lightning impulse experiments with both polarities were conducted on rod-plane and plane-plane electrode configurations. For the investigation in this paper, a mixture ratio of 30/70% for both CF₃I/CO₂ and CF₃I/N₂ gas mixtures were tested.

A. Effect of Gas Pressure, Gap Distance and Impulse Polarity

Breakdown characteristics of a 30/70% $\text{CF}_3\text{I}/\text{CO}_2$ gas mixture using rod-plane and plane-plane electrode configurations were investigated and reported in [16]. The range of experimental data was able to provide an indication on the influence of gas pressure, gap distance and impulse polarities for a $\text{CF}_3\text{I}/\text{CO}_2$ gas mixture. As pressure increases from 1 to 2 bar, the breakdown voltage increases but at a slower rate, as shown in Fig. 5. However, it is unclear from the available data that higher rate of saturation in the breakdown results is expected at higher gas pressures.

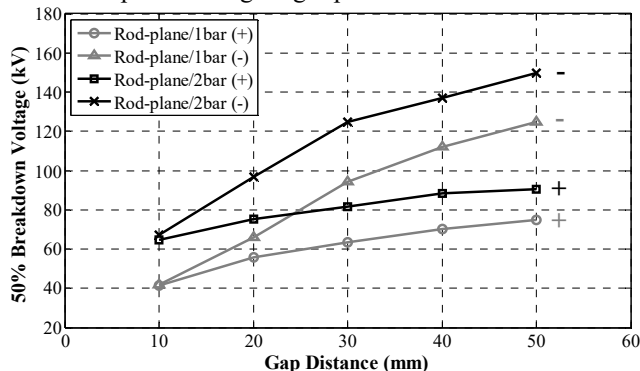

Fig. 5. U_{50} as a function of gap distance in a rod-plane electrode configuration and investigated for a 30/70% $\text{CF}_3\text{I}/\text{CO}_2$ gas mixture at pressures of 1 and 2 bar (abs.) and for both lightning impulse polarities.

The effect of gap distance was tested for plane-plane and rod-plane electrode configurations. The breakdown voltage measured towards higher gap distances is increasing but with decreasing rate, as shown in Fig. 6.

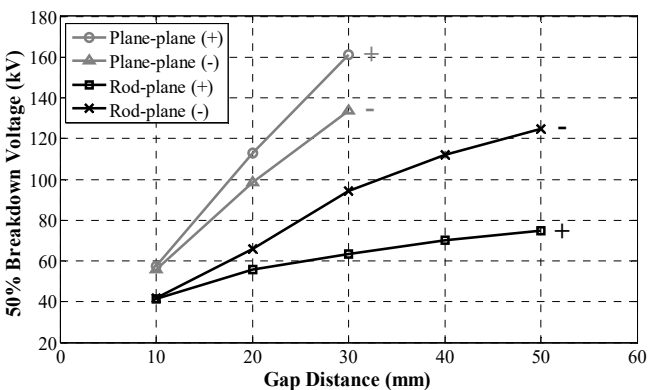

Fig. 6. U_{50} as a function of gap distance in a plane-plane and a rod-plane electrode configurations, tested using a 30/70% $\text{CF}_3\text{I}/\text{CO}_2$ gas mixture at 1 bar (abs.) and for both lightning impulse polarities.

It can be seen from both Fig. 5 and Fig. 6 that the breakdown results for negative polarity are higher than those for positive polarity in a rod-plane configuration. In the case of a positive rod, ionization accelerates electron collision in the high field region near the rod. Electrons are readily drawn towards the anode and, with time, the field strength near the rod is sufficiently high to initiate a complete breakdown. For a negative rod, the electrons are accelerated into the low field region by the cathode and, during the process, they become

attached to strongly attaching gases like CF_3I or SF_6 [17]. This slows down the ionization process, which then requires a higher voltage to initiate a complete breakdown. Similar breakdown characteristics on a rod-plane electrode for standard lightning impulses (1.2/50) were also reported by other researchers for CF_3I [18].

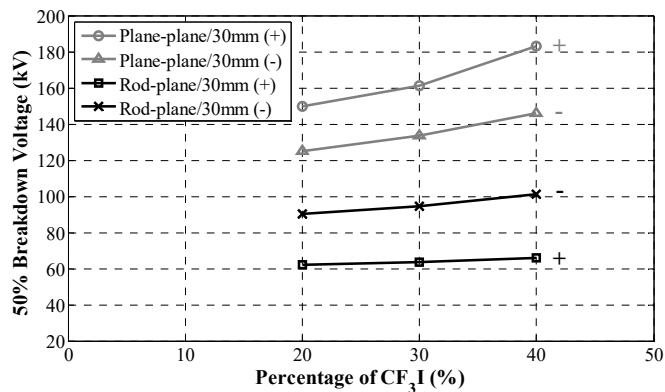

Fig. 7. U_{50} as a function of $\text{CF}_3\text{I}/\text{CO}_2$ gas mixtures in a rod-plane electrode configuration for a gap distance of 30 mm at 1 bar (abs.) and for both lightning impulse polarities.

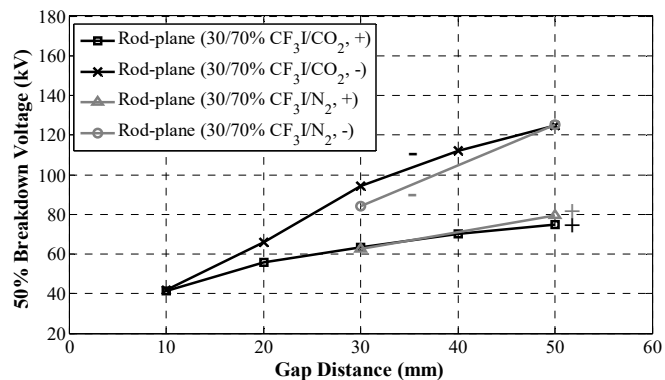

Fig. 8. U_{50} as a function of gap distance of 10 to 50 mm in a rod-plane electrode configuration, tested using a mixture ratio of 30/70% for both $\text{CF}_3\text{I}/\text{CO}_2$ and $\text{CF}_3\text{I}/\text{N}_2$ gas mixtures at 1 bar (abs.) and for both lightning impulse polarities.

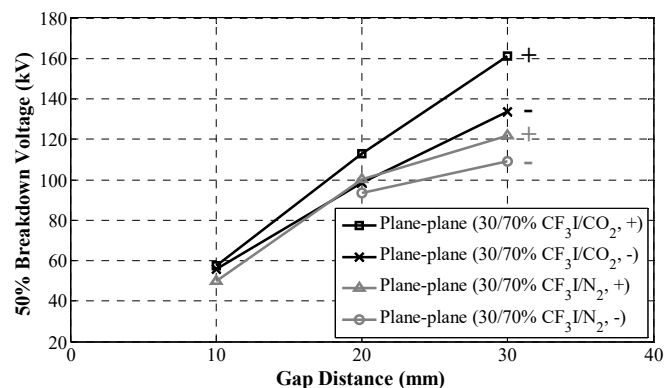

Fig. 9. U_{50} as a function of gap distance of 10 to 30 mm in a plane-plane electrode configuration, tested using a mixture ratio of 30/70% for both $\text{CF}_3\text{I}/\text{CO}_2$ and $\text{CF}_3\text{I}/\text{N}_2$ gas mixtures at 1 bar (abs.) and for both lightning impulse polarities.

B. Effect of Mixture Content and Buffer Gas

Tests were carried out for CF₃I/CO₂ gas mixture ratios of 20/80%, 30/70% and 40/60% at a pressure of 1 bar (abs.) in rod-plane and plane-plane electrode configurations for a fixed gap distance of 30 mm. As can be seen, an increase in CF₃I content results in a higher breakdown strength, as illustrated in Fig. 7. However, for a binary gas mixture with high CF₃I content, lower pressures are required to avoid liquefaction, and more by-products are likely to be generated per breakdown.

An investigation was also conducted for CF₃I gas mixtures mixed with CO₂ and N₂ as buffer gas. For a 30/70% mixture ratio, the test results are shown in Fig. 8 and Fig. 9. It can be seen in Fig. 8 that there is a small difference in breakdown results of a rod-plane configuration for both CF₃I/CO₂ and CF₃I/N₂ gas mixtures under both impulse polarities. However, changing the buffer gas has a more profound effect on U₅₀ in a plane-plane configuration. Results for CF₃I/N₂ are comparably lower than their CF₃I/CO₂ counterpart (see Fig. 9).

C. Breakdown Field Strength of 30/70% CF₃I/CO₂ Gas Mixture in Uniform and Non-uniform Geometries

In order to generalise the information obtained from the experiment, the measured U₅₀ values are converted into the pressure-normalised maximum breakdown field strength (E_{max}/p)_B. This can be calculated using (2) which is adopted from [19].

$$(E_{\max}/p)_B = (E/p)_{\text{crit}} + \frac{K}{k(pd)} \quad (2)$$

where (E/p)_{crit} is the critical reduced field strength, k is the primary ionization coefficient and K is the streamer mechanism (K=18). The (E/p)_{crit} and k values are obtained using BOLSIG+ for when (α - η) = 0 for each gas or gas mixture.

By adopting (2), the breakdown field strength values for SF₆ and 30/70% CF₃I/CO₂ gas mixture were calculated, and are shown in Fig. 10. As can be observed, there is good agreement between the measured and calculated results for 30/70% CF₃I/CO₂ gas mixture [16]. The SF₆ data [20–21] appears to show less agreement, which may be due to surface defects as opposed to the mirror finish used in CF₃I testing. SF₆ is known to be very sensitive to change in E/p, especially in the presence of defects on the surface of the electrodes.

In the case of non-uniform field gaps, Equation (3) was proposed by Howard [22] for calculating the field strength in non-uniform field breakdown for electronegative gas.

$$(E_{\max}/p)_B = \frac{2 \cdot U_b}{R \cdot \ln(4g/R)} \quad (3)$$

where R is the radius of curvature of the point tip, g is the gap spacing and U_b is the measured breakdown voltage.

The breakdown field strength can also be obtained using COMSOL software, which require the dimension of the test configuration and the measured breakdown voltage. By using

COMSOL, the (E_{max}/p)_B values were obtained and are shown in Fig. 11 for 30/70% CF₃I/CO₂ gas mixture.

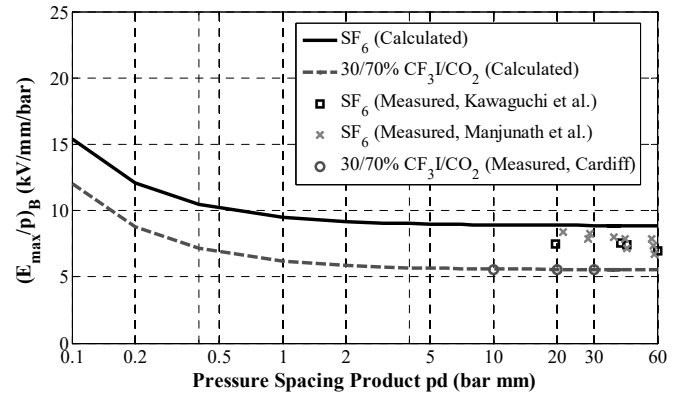

Fig. 10. Characteristics of (E_{max}/p)_B in uniform gaps for SF₆ and 30/70% CF₃I/CO₂ gas mixture for both calculated and measured data and for positive lightning impulse.

Based on the available data, the (E_{max}/p)_B is shown to decrease with pressure towards the (E/p)_{crit} of the test gas mixture. It has been observed in the literature for SF₆ in quasi-uniform field gaps, that the (E_{max}/p)_B drops below the (E/p)_{crit} at higher gas pressures [23]. It is unclear from Fig. 11 whether a similar trend characteristic can be expected for a CF₃I/CO₂ gas mixture and in non-uniform field gaps. Further experimental works are required at higher pressures and more choice of curvature radius on the rod tip.

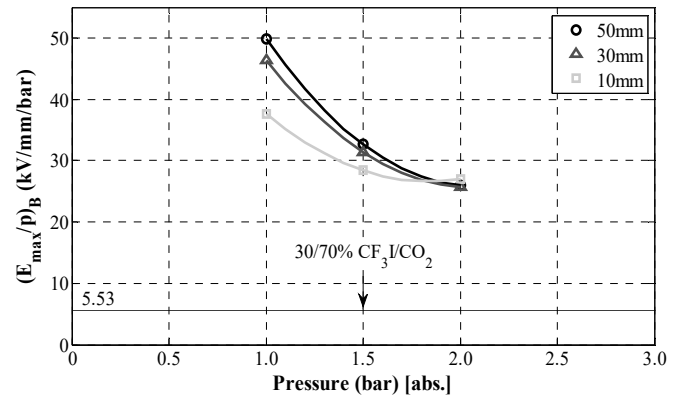

Fig. 11. Characteristics of (E_{max}/p)_B for 30/70% CF₃I/CO₂ gas mixture at pressure of 1 to 2 bar (abs.), tested on non-uniform gaps and for positive lightning impulse.

V. INVESTIGATION OF 30/70% CF₃I GAS MIXTURES IN COAXIAL GIL TEST SYSTEM

In gas-insulated equipment, a gas can be used as an insulation medium for application in GIL. Construction of a full-scale GIL is quite costly. For the initial experimental work, a reduced-scale coaxial GIL test system that has similar electric field distribution as a full-scale GIL was designed, developed and fabricated. The initial test results are presented in this section to provide an indication on the breakdown strength of CF₃I gas mixtures and the feasibility for application in GIL.

A. Dimensioning of coaxial system

Fig. 12 depicts a proposed coaxial cylindrical structure for the scaled test GIL, with R_a the outer conductor radius and R_b the inner enclosure radius.

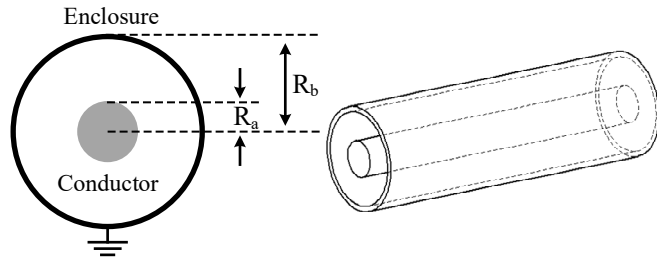

Fig. 12. Cross-section view of a coaxial geometry.

Given the known electric field distribution in a coaxial system, the highest field is expected at the surface of the inner conductor, from where breakdown is likely to be initiated. Equation (4), which gives the maximum field at the inner conductor surface, is used to calculate the optimised radii R_a and R_b for the scaled prototype. For this work, R_a and R_b need to be small enough so that the whole GIL prototype fits inside the available test pressure vessel and can withstand the voltage limitation of the high-voltage bushing of the vessel (170 kV lightning impulse). As a result, for the 30/90 mm coaxial test system, the test was only conducted up to 0.5 bar (abs.).

$$E = \frac{U}{R_a \cdot \ln(R_b/R_a)} \quad (4)$$

The breakdown electric field magnitude, E_b , is obtained for an applied voltage U_b on the inner conductor. In this case, (4) can be re-written as (5).

$$U_b = E_b \cdot R_a \cdot \ln\left(\frac{R_b}{R_a}\right) \quad (5)$$

An important factor that needs to be taken into consideration for the design is the optimisation of the gap ratio, which improves field uniformity in a coaxial geometry. As demonstrated in [19, 24], designing the coaxial system so that the quantity $\ln(R_b/R_a)$ has a value of unity is considered to satisfy the optimal condition. If R_b is fixed and E_b assumed constant, the optimal design for our coaxial geometry was achieved adopting $\ln(R_b/R_a) \approx 1$.

As reported previously [19, 24–25], operational GIL systems worldwide have adopted this optimal ratio for their geometric dimensioning. AZZ CGIT, a major manufacturer of GIL, gives details of the dimensions of GIL systems [25] with rated voltages of 145 kV to 1200 kV. Here, we plot in Fig. 13 the equivalent lightning impulse withstand voltages against the geometric ratios of the GIL.

As can be observed on the figure, most of the GIL dimensions have ratios of 1 to 2.718 (optimal) or 3. However, in the case of 800 kV and 1200 kV rated GIL, the geometric ratio tends to be much larger than that of lower rated GIL. This may indicate that the field uniformity in the GIL is less important than the gap spacing for very high voltage applications. Such effects were investigated for CF₃I gas

mixtures in [26–27], with the diameter of the outer electrode fixed and using different radii of inner conductors. The conclusion from this investigation indicates that, in coaxial test systems, the highest breakdown strength is dependent on the quantity $\ln(R_b/R_a)$, and is independent of the test gas or gas mixture.

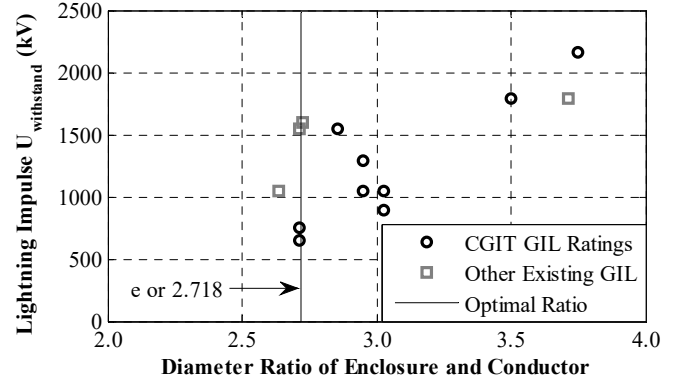

Fig. 13. Relationship between lightning impulse withstand voltage and dimensions in existing GIL systems.

B. Geometric Dimensioning of the Prototype

In this investigation, the laboratory coaxial test GIL scaled prototypes were designed with ratios enclosure to conductor between 1 and 3. Such ratios are similar to those adopted for the majority of existing GIL systems at 400 kV. In other work by the authors, tests were conducted on a coaxial test system of 10/30 mm [26]. The work in this section extended the geometry to 30/90 mm. Results of CF₃I gas mixtures at a larger coaxial electrode configuration allows us to draw conclusions on extrapolations of breakdown voltages.

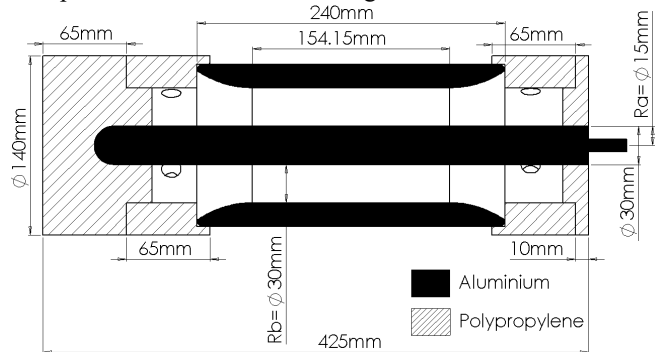

Fig. 14. Design schematic of constructed reduced-scale coaxial GIL laboratory system. The values of “ R_a ” and “ R_b ” correspond to the radius of outer conductor and inner enclosure.

Fig. 14 illustrates the geometry details of the constructed GIL laboratory prototype. A curvature radius was implemented on the inner wall of the outer conductor to reduce end effects on electric field magnitude, and this is expected to reduce the likelihood of breakdown at the edges of the enclosure.

The conductor length was designed in such a way that it can be positioned well inside the support insulator. Consequently, the clearance gap between the conductor tip and the enclosure wall was increased significantly.

> REPLACE THIS LINE WITH YOUR PAPER IDENTIFICATION NUMBER (DOUBLE-CLICK HERE TO EDIT) < 7

C. Simulation Modelling

When the critical field strength, E_{crit} , of the insulating gas mixture is exceeded at the conductor surface in a coaxial test system with a geometric ratio $R = R_b/R_a$, corona will be initiated. The inception critical field occurs at a voltage $U > U_{inception}$. Without formation of any leader channel, the streamer breakdown voltage U_S is expressed as (6).

$$U_S = E_{crit} \cdot (R_b - R_a) \quad (6)$$

In order to identify regions of high field and fine tune the geometry, a numerical simulation of the coaxial system was performed using COMSOL multiphysics. As expected within the design, and can be observed on Fig. 15, the maximum electric field is computed around the central region of the surface of the inner conductor. The field strength is lower at the ends of the enclosure, which is facilitated by the profiled design. Such design will minimise breakdown occurrences at the ends of the test system and will encourage more breakdown events to occur around the central region.

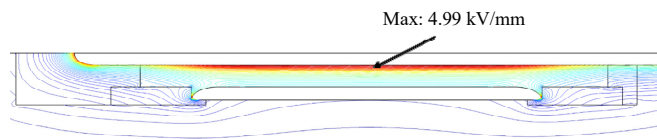

Fig. 15. Computed electric field distribution in coaxial rig for an applied voltage of 83 kV (the maximum electric field occurs around the centre region).

A coaxial test system with inner/outer cylinder geometry of 30/90mm was fabricated to represent a reduced-scale coaxial GIL test system (Fig. 16). Aluminium was used to machine both the enclosure and the conductor, and the insulating spacers and holders were made from polypropylene. As clearly visible on the photo of Fig. 16, a number of holes were machined in the insulators to facilitate easy and free circulation of the CF_3I gas mixture throughout the coaxial test system. In order to connect the tip of the conductor to the bushing, a 10 mm thread was used.



Fig. 16. Photograph of the reduced-scale coaxial test system showing the holes in the insulators to allow easy gas circulation.

D. Results and Discussions

Tests were conducted on the coaxial test system to examine the breakdown performance of CF_3I gas mixture in a coaxial GIL test configuration. The results are shown in Table II, at a low pressure of 0.5 bar (abs.), the measured results are comparable for both CF_3I/CO_2 and CF_3I/N_2 gas mixtures. For a coaxial geometry of 11.1/28.5 mm with a gap of 8.7 mm, the

U_{50} at 0.5 bar (abs.) for 30/70% CF_3I/CO_2 gas mixture was reported to be 31 kV [27]. In comparison, the 30/90 mm coaxial test system is around 3.4 times larger in terms of the dimensions of the gap spacing but the breakdown voltage is only 2.5 times higher in relation to U_{50} . This suggests that U_{50} is not increasing linearly with gap spacing as the geometric ratio of the two coaxial test systems are different. This also indicates that the optimal ratio for designing an SF_6 coaxial test system applies to other gases such as CF_3I . The results in Table II show that CF_3I/CO_2 and CF_3I/N_2 gas mixtures had polarity effects opposite to each other. This requires further investigation in order to establish a more definitive conclusion regarding the polarity effect introduced by the buffer gas.

Table III summarises the measured and predicted electric field values. Under atmospheric pressure at 0.5 bar (abs.), if the primary streamer extends to bridge the inter-electrode gap in the coaxial system, a streamer breakdown will be initiated when $U_b = U_S$. Subsequently, this value is used in (4) to calculate E_{max} and in the numerical computation to determine the electric field distribution and its associated E_{max} magnitude. Furthermore, the measured U_{50} was utilised in (7) to calculate $(E_{max}/p)_B$ value.

$$(E_{max}/p)_B = \frac{U_{50}}{R_a \cdot \ln(R_b/R_a) \cdot p} \quad (7)$$

Using these various approaches to determine E_{max} , i.e. measurements, simplified equation and full numerical computations, good agreement was obtained as can be seen in Table III.

However, there is a potential drop in the measured U_{50} for longer gap distances and higher pressures, which may be attributed to the formation of a self-propagating leader channel. This channel, in turn, may initiate a leader breakdown across the coaxial electrode gap. Work is on-going within the research group to develop a mathematical model which takes into account the drop in potential and its relationship with the streamer/leader processes. This will be communicated in a future publication.

TABLE II
Comparison of measured breakdown voltage at 0.5 bar (abs.) for 30/70% CF_3I gas mixtures.

Gas Mixture	Positive (kV)	Negative (kV)
30/70% CF_3I/CO_2	78.4	75.2
30/70% CF_3I/N_2	78.2	80.0

TABLE III
Predicted and measured maximum electric field magnitudes (0.5 bar (abs.) using 30/70% CF_3I gas mixtures under positive lightning impulse).

	30/70% CF_3I/CO_2 (kV/mm/bar)	30/70% CF_3I/N_2 (kV/mm/bar)
Calculated E_{max}	5.03	5.71
Simulated E_{max}	4.99	5.66
Experimental $(E_{max}/p)_B$	4.76	4.75

VI. INVESTIGATION OF 30/70% CF₃I/CO₂ GAS MIXTURE FOR APPLICATION IN SWITCHGEAR

With the promising insulation properties of the 30/70% CF₃I/CO₂ gas mixture, measured by the authors and other researchers, a trial test programme was carried out using this gas mixture as the insulation gas in a commercial SF₆-filled ring main unit (RMU). The RMU consists of two low-current ring switches and a tee-off vacuum circuit breaker that is housed in an SF₆ gas insulated chamber. Fig. 17 shows a schematic of the tested RMU. The test setup for the low-current switches is indicated in Fig. 17(a) whilst the test arrangement for the circuit breaker is illustrated in Fig. 17(b). During the test campaign, a 1.4 bar (abs.) rated filling pressure of the RMU was used for the 30/70% CF₃I/CO₂ gas mixture.

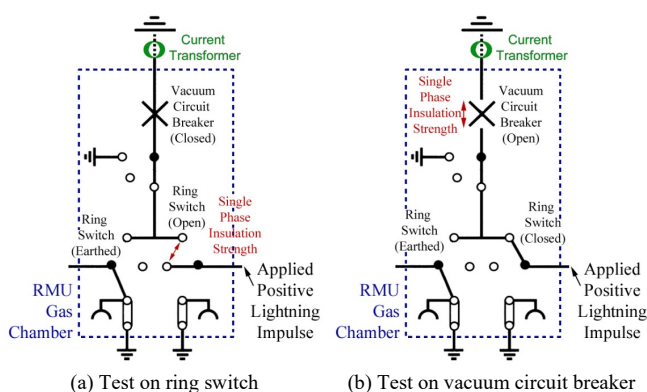

Fig. 17. Test arrangements for RMU filled with 30/70% CF₃I/CO₂ gas mixture.

The SF₆-filled RMU has a rated impulse withstand voltage of 75 kV. The RMU filled with 30/70% CF₃I/CO₂ was, therefore, tested in accordance with procedure B as specified in BS60060-1 [14]. This test procedure has been adapted for switchgear and controlgear as described in BS62271-1 [15]. For the breakdown voltage tests, a series of 75 kV positive lightning impulses were applied to each phase in turn. For the switch tests (Fig. 17 (a)), 25 impulses were applied to each phase to determine the withstand strength of the CF₃I/CO₂ gas mixture. On the other hand, for the vacuum circuit breaker tests (Fig. 17 (b)), two sets of 25 impulses were used on each phase of the RMU. In all tests, a current transformer measurement was utilised to indicate gas breakdown events within the RMU equipment.

The breakdown test results are summarised in Table IV. As can be observed, for the RMU filled with 30/70% CF₃I/CO₂ gas mixture, no breakdown event was recorded for the switch and breaker tests. Such observation allows us to suggest that the 30/70% CF₃I/CO₂ gas mixture is a potential candidate to replace SF₆ gas for insulation duties in 11 kV RMU.

In this investigation, however, the current interruption capability of the 30/70% CF₃I/CO₂ gas mixture has not been assessed experimentally due to lack of a suitable high current test source. Therefore, future work is planned to explore the current interruption capability of such gas mixture.

TABLE IV

Number of breakdown events/number of shots for breakdown tests on 30/70% CF₃I/CO₂ gas mixture tested with 75 kV positive lightning impulses.

No. of Gas Breakdown	Ring Switch	Circuit Breaker
Phase 1	0/25	0/50
Phase 2	0/25	0/50
Phase 3	0/25	0/50
RMU Average	0/75	0/150

VII. CONCLUSION

This paper highlights the results of work conducted on CF₃I gas mixtures as potential replacements for SF₆ insulation gas in high-voltage equipment. Tests were conducted on several test configurations (rod-plane, plane-plane and coaxial GIL) to characterise the electrical performance of CF₃I gas mixtures. The effect of gas pressure, gap distance, impulse polarity, mixture content and buffer gas were investigated experimentally. The breakdown test results obtained in this work indicate that the insulation properties of the proposed gas mixture could be a practical alternative candidate to replace SF₆ gas in GIL insulation applications. However, CF₃I current interruption capabilities have not been proven yet, and further work is needed in this area. The build-up of iodine deposition after electrical discharge was observed and its effect need to be quantified if current interruption is to be considered. Again, this needs to be further investigated.

In addition, trial laboratory tests are underway on a full-scale 400 kV GIL demonstrator that has been assembled at Cardiff University. As the demonstrator was designed for SF₆, this work will address the issues associated with retrofitting existing SF₆ equipment with the proposed CF₃I gas mixtures. Work on this full-scale demonstrator will provide a better assessment of the capabilities of CF₃I gas mixtures in full practical GIL systems at transmission voltages.

Further experimentation is required on coaxial GIL test system (30/90 mm) at higher gas pressure and work on practical circuit breaker contact electrode configurations using a CF₃I gas mixture is also envisaged.

REFERENCES

- [1] O. Farish, M. D. Judd, B. F. Hampton and J. S. Pearson, "SF₆ insulation systems and their monitoring", *Advances in High Voltage Engineering*, edited by A. Haddad and D. Warne, London, UK: IET, ch. 2, pp. 38-45, 2009.
- [2] L. G. Christophorou and J. K. Olthoff, "Electron Interactions With CF₃I", *J. Phys. Chem. Ref. Data*, vol. 29, no. 4, pp. 553-569, 2000.
- [3] EPA 430-R-02-003, "Inventory of U.S. Greenhouse Gas Emissions and Sinks: 1990-2000", *Office of Atmospheric Programs, U.S. Environmental Protection Agency*, Washington, USA, 2002.
- [4] Y. Y. Duan, M. S. Zhu, and L. Z. Han, "Experimental vapor pressure data and a vapor pressure equation for trifluoroiodomethane (CF₃I)", *Fluid Phase Equilibria*, vol. 121, pp. 227-234, 1996.
- [5] S. Solomon, B. Burkholder, A. R. Ravishankara, and R. Garcia, "Ozone depletion and global warming potentials of CF₃I", *J. Geophys. Res.*, vol. 99, no. D10, pp. 20929-20935, 1994.
- [6] G. J. M. Hagelaar and L. C. Pitchford, "Solving the Boltzmann equation to obtain electron transport coefficients and rate coefficients for fluid models", *Plasma Sources Sci. Technol.*, vol. 14, no. 4, pp. 722-733, 2005.

- [7] J. Urquijo, A. Mitrani, G. Ruiz-Vargas and E. Basurto, "Limiting field strength and electron swarm coefficients of the CF₃I-SF₆ gas mixture", *J. Phys. D: Appl. Phys.*, vol. 44, 342001 (3pp), 2011.
- [8] D. Tanaka, A. Kumada, and K. Hidaka, "Numerical Simulation of Streamer Development in CF₃I-N₂ Gas Mixtures", *17th Int'l. Symp. High Voltage Eng.*, A-14, Hannover, Germany, 2011.
- [9] T. Takeda, S. Matsuoka, A. Kumada, and K. Hidaka, "By-product Generation through Electrical Discharge in CF₃I Gas and its Effect to Insulation Characteristics", *IEEE Trans. Power and Energy*, vol. 131, no. 10, pp. 859-864, 2011.
- [10] H. Katagiri, H. Kasuya, H. Mizoguchi, and S. Yanabu, "Investigation of the performance of CF₃I Gas as a Possible Substitute for SF₆", *IEEE Trans. Dielectr. Electr. Insul.*, vol. 15, no. 5, pp. 1424-1429, 2008.
- [11] W. C. McCain and J. Macko, "Toxicity Review for Iodotrifluoromethane (CF₃I)", in *Halon Options Technical Working Conference*, project no. 85-8823-99, pp. 242-253, Albuquerque, NM, USA, 1999.
- [12] Subcommittee on Iodotrifluoromethane, *Iodotrifluoromethane: Toxicity Review*, Washington, USA: The National Academies Press, 2004.
- [13] "CGA P-20: Standard for the Classification of Toxic Gas Mixtures", *Compressed Gas Association*, 3rd ed., 2013.
- [14] "BS EN 60060-1: High-voltage test techniques - Part 1: General definitions and test requirements", *British Standard Institution*, 2010.
- [15] "BS EN 62271-1: High-voltage switchgear and controlgear - Part 1: Common specifications", *British Standard Institution*, 2008.
- [16] M. S. Kamarudin, A. Haddad, and S. J. Macgregor, "Experimental investigation of CF₃I-CO₂ gas mixtures under lightning impulses", *20th Int'l Conf. Gas Discharges and their Applications*, C-4, Orleans, France, 2014.
- [17] L. G. Christophorou, J. K. Olthoff, and D. S. Green, "Gases for Electrical Insulation and Arc Interruption: Possible Present and Future Alternatives to Pure SF₆", *NIST Technical Note 1425*, Washington, USA, pp. 1-44, 1997.
- [18] M. N. Ngoc, A. Denat, N. Bonifaci, O. Lesaint, and M. Hassanzadeh, "Impulse partial discharges and breakdown of CF₃I in highly non-uniform field", *18th Int'l Conf. Gas Discharges and their Applications*, Greifswald, Germany, 2010. pp. 330-333.
- [19] E. Kuffel, W. S. Zaengl, and J. Kuffel, *High Voltage Engineering - Fundamentals*, 2nd ed., Oxford, UK: Newnes, 2000.
- [20] Y. Kawaguchi, K. Sakata, and S. Menju, "Effect of a Grounded Cylinder Enclosure on the Breakdown Gradient of Rod Gaps in SF₆", *IEEE Trans. Power App. Syst.*, vol. PAS-90, no. 3, pp. 1079-1085, 1970.
- [21] B. S. Manjunath, K. Dwarakanath, K. S. Arunachala Sastry, and K. N. Ravi, "Uniform field breakdown in SF₆ gas at high pressures under lightning and switching surge voltages", *IEEE Conf. Electr. Insul. Dielectr. Phenomena*, Ottawa, Canada, 1988. pp. 329-333.
- [22] P. R. Howard, "Process contributing to the breakdown of electronegative gases in uniform and non-uniform electric fields", *Proc. IEE - Part A: Power Eng.*, vol. 104, no. 14, pp. 139-142, 1957.
- [23] S. Menju, H. Aoyagi, K. Takahashi, and H. Ohno, "Dielectric Breakdown of High Pressure SF₆ in Sphere and Coaxial Cylinder Gaps", *IEEE Trans. Power App. Syst.*, vol. PAS-93, no. 5, pp. 1706-1712, 1974.
- [24] H. Koch, "Basic information on gas insulated transmission lines (GIL)", *Power and Energy Society General Meeting*, pp. 1-4, Pittsburgh, PA, USA, 2008.
- [25] "Compressed Gas Insulated Transmission Bus Systems - Proven Solutions for Power Transmission", *AZZ CGIT Technical Brouchure 001*, Westborough, MA, USA, 2004.
- [26] L. Chen, P. Widger, M. S. Kamarudin, H. Griffiths, and A. Haddad, "Potential of CF₃I Gas Mixture as an Insulation Medium in Gas-Insulated Equipment", *IEEE Conf. Electr. Insul. Dielectr. Phenomena*, 237, Ann Arbor, MI, USA, 2015. pp. 868-871.
- [27] L. Chen, "Investigation on the Feasibility of Trifluoroiodomethane (CF₃I) for Application in Gas-Insulated Lines", Ph.D. thesis, Cardiff University, UK, 2015.



P. Widger received the Ph.D. and B.Eng. degrees in electrical and electronic engineering from Cardiff University, UK in 2014 and 2010 respectively. Between 2010 and 2014, he worked towards his Ph.D. degree in the Advanced High Voltage Engineering Research Centre at Cardiff University. Since then he has worked as a research associate at Cardiff University. His research is focused on alternatives gases to SF₆, specialising in gas mixtures of CF₃I, for use in distribution and transmission networks.



M. S. Kamarudin received his B.Eng. and M.Eng. Degrees in Electrical Engineering (Power) from Universiti Teknologi Malaysia (UTM) in 2003 and 2005, respectively and a Ph.D. in High Voltage Engineering from Cardiff University, UK, in 2014. Currently, he is a senior lecturer in the Faculty of Electrical and Electronic Engineering at Universiti of Tun Hussein Onn Malaysia (UTHM). His research interests include gas discharges, high voltage surge arresters and dielectrics and electrical insulation systems.



H. Griffiths obtained a BSc. degree in Electrical and Electronic Engineering from the Polytechnic of Wales and a Ph.D. in Electrical Engineering from Cardiff University. Between 1983 and 1990, he worked at the South Wales Electricity Board and the Central Electricity Generating Board in distribution and transmission system design. In 1990, he was appointed to the lecturing staff at Cardiff University. He is now Professor in the High Voltage Group and at the Petroleum Institute, Abu Dhabi, UAE where he is currently based. His research interests include earthing systems and high voltage insulation. He is a member of a number of BSI, CENELEC, IEC, CIGRE and CIREN working groups and committees. He is a chartered engineer and a member of IET and IEEE.



A. Haddad (M'13) received the degree of Ingénieur d'État in electrical engineering in 1985 and the Ph.D. degree in high-voltage engineering in 1990. He is currently a Professor of Electrical Engineering with Cardiff University responsible for research in high-voltage engineering. He has authored an IET- Power Series Book entitled *Advances in High-Voltage Engineering*. His research interests are in overvoltage protection, insulation systems, insulation coordination, and earthing of electrical energy systems. He is a member of several CIGRE Working Groups and a member of the BSI PEL1/2, the IEC TC37 and the IEC ACTAD committees MT4 and MT10. He serves on the scientific committees of several international conferences. He is a fellow of the IET and the Learned Society of Wales.



L. Chen (M'13) obtained a B.Eng. (Hons) degree in Electrical & Electronic Engineering in 2012 and then a Ph.D. in High Voltage Engineering in 2015 from Cardiff University, UK. He is currently working on the characterisation of CF₃I in a gas-insulated line (GIL) demonstrator. His research interests are concerned with the feasibility of replacing SF₆ with an environmentally friendly insulation medium in gas-insulated equipment.