

Measurement of the binaural auditory filter using a detection task

Andrew J. Kolarik and John F. Culling

School of Psychology, Cardiff University, Tower Building, Park Place, Cardiff CF10 3AT, United Kingdom

(Received 30 July 2007; revised 5 February 2010; accepted 22 February 2010)

The spectral resolution of the binaural system was measured using a tone-detection task in a binaural analog of the notched-noise technique. Three listeners performed 2-interval, 2-alternative, forced choice tasks with a 500-ms out-of-phase signal within 500 ms of broadband masking noise consisting of an “outer” band of either interaurally uncorrelated or anticorrelated noise, and an “inner” band of interaurally correlated noise. Three signal frequencies were tested (250, 500, and 750 Hz), and the asymmetry of the filter was measured by keeping the signal at a constant frequency and moving the correlated noise band relative to the signal. Thresholds were taken for bandwidths of correlated noise ranging from 0 to 400 Hz. The equivalent rectangular bandwidth of the binaural filter was found to increase with signal frequency, and estimates tended to be larger than monaural bandwidths measured for the same listeners using equivalent techniques.

© 2010 Acoustical Society of America. [DOI: 10.1121/1.3365314]

PACS number(s): 43.66.Ba, 43.66.Dc, 43.66.Pn [RYL]

Pages: 3009–3017

I. INTRODUCTION

Since the early work of Fletcher (1940) who conceived the critical-band model of frequency selectivity, monaural frequency selectivity has been studied extensively (e.g., Moore *et al.*, 1990; Glasberg and Moore, 2000; Baker and Rosen, 2006). These studies indicate that at low frequencies, auditory filters tend to be asymmetric on a log-log scale, with a shallower lower slope than upper slope, and become less asymmetric and narrower as frequency is increased (Baker and Rosen, 2006). Relatively few studies have investigated the bandwidth of binaural auditory filters, and these have presented conflicting findings that indicate that binaural frequency resolution is either comparable to monaural resolution (e.g., Kohlrausch, 1988) or poorer (e.g., Sondhi and Guttman, 1966). One way to reconcile these results is to suppose that binaural and monaural frequency selectivity are equivalent, but that measurements of binaural resolution are influenced by a range of frequencies that include information from filters adjacent to the filter centered at the signal, resulting in a wider operational bandwidth that is dependent on the spectral content of the masker (van der Heijden and Trahiotis, 1998; van de Par and Kohlrausch, 1999; Bernstein *et al.*, 2006). Alternatively, there may have been differences in outcome associated with the various measurement techniques previously employed to measure binaural filter bandwidths. The present study is an attempt to bring monaural and binaural measurement techniques into closer alignment.

Sondhi and Guttman (1966) used broadband noise to mask a low-frequency tone in a variety of configurations at two signal frequencies (250 and 500 Hz). The masker was divided into three successive bands, where the interaural phase of the “inner” band was antiphase with respect to the “outer” bands. The inner band was spectrally centered around the signal. The following notation, a variant of that widely used in binaural unmasking, is used to describe the stimuli. The subscript following the N symbol describes the

interaural phase at the two ears of successive frequency bands of the noise, and the subscript following the S symbol describes the interaural phase of the signal. For example, in the $N_{\pi 0 \pi} S_{\pi}$ configuration (see Fig. 1), the interaural phase of the masker was set to zero for the frequency band surrounding an out-of-phase tone (S_{π}), while noise components outside the band were set to π ($N_{\pi 0 \pi}$). In these terms, the four stimulus configurations that were tested by Sondhi and Guttman (1966) were $N_{0 \pi 0} S_0$, $N_{\pi 0 \pi} S_0$, $N_{0 \pi 0} S_{\pi}$, and $N_{\pi 0 \pi} S_{\pi}$, and masked thresholds were obtained for a range of bandwidths (B) of the inner band of the masker.

As their study predated the use of the equivalent rectangular bandwidth (ERB) (Glasberg and Moore, 1990) as a common measure of auditory filter bandwidth, Sondhi and Guttman (1966) defined the width of the binaural critical bandwidth as the value of B at which the release of masking in the antiphase inner band conditions was half of the maximum binaural masking level difference (BMLD). They obtained values of 125 Hz at a signal frequency of 250 Hz, and 200 Hz at a signal frequency of 500 Hz.

Kohlrausch (1988) measured binaural frequency selectivity with a different technique. He gave listeners a task in which they had to detect a signal presented either monaurally (S_m), binaurally in-phase (S_0), or binaurally out-of-phase (S_{π}), within a broadband masker that was in-phase below 500 Hz and out-of-phase at higher frequencies, denoted $N_{0 \pi} S_{\pi}$ (or vice versa, $N_{\pi 0} S_{\pi}$). Signal thresholds were measured at frequencies between 200 and 800 Hz for each binaural configuration (see Fig. 2).

He used this design in order to measure the shape of the binaural auditory filter, as it could be calculated from the values of binaural masked thresholds at different signal frequencies around the phase transition frequency. The best fit to the data was found to be made by a trapezoidal filter¹ with an ERB of 80–84 Hz. These values were highly comparable to the monaural ERB value (84.6 Hz) measured by Patterson

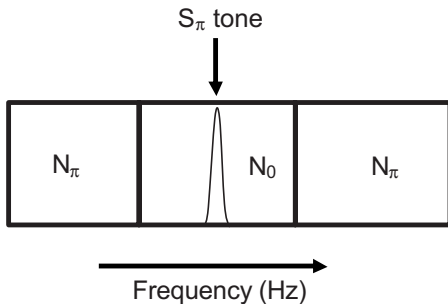

FIG. 1. A schematic of the stimuli used by [Sondhi and Guttman \(1966\)](#). The stimulus configuration in this example is $N_{\pi}S_{\pi}$.

(1976), which [Kohlrausch \(1988\)](#) attributed to the similarity in filter shape between the two studies (see Fig. 16 of [Kohlrausch, 1988](#)).

[Holube et al. \(1998\)](#) conducted an extensive study that contrasted monaural and binaural filter bandwidths using the same listeners, equipment, psychophysical procedure, and model assumptions. They obtained bandwidth measurements for a variety of methods, including stepwise variations in masker correlation/power density comparable to the experimental design employed by [Kohlrausch \(1988\)](#) and [Patterson \(1974\)](#), respectively, and rectangular masker variations (with two transitions) comparable to the design of the studies conducted by [Sondhi and Guttman \(1966\)](#) and [Patterson \(1976\)](#). They found that in the majority of cases, binaural bandwidths were similar to or larger than comparable monaural bandwidths. For both binaural and monaural stimuli, stepwise designs [comparable to [Kohlrausch's \(1988\)](#) study] yielded the lowest bandwidths, and rectangular designs [comparable to [Sondhi and Guttman's \(1966\)](#) study] produced the lowest variability.

II. MEASUREMENTS

Some differences in binaural auditory filter bandwidths obtained from different studies may stem from methodological problems associated with the experimental design. One potential problem is that when dichotic broadband noise switches from in-phase to out-of-phase over a narrow frequency region, a percept called the binaural edge pitch

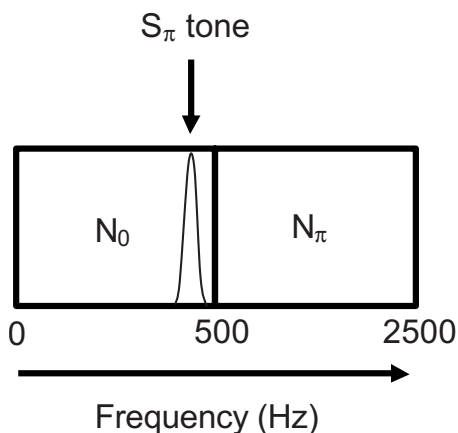

FIG. 2. A schematic example of the stimuli used by [Kohlrausch \(1988\)](#). In this example, the stimulus configuration is $N_{0\pi}S_{\pi}$.

(BEP) is created ([Klein and Hartmann, 1981](#)). This is a sensation of pitch at the frequency where the phase transition occurs, similar to the Huggins pitch ([Cramer and Huggins, 1958](#)), and is strongest for frequency regions between 350 and 800 Hz ([Klein and Hartmann, 1981](#)). The presence of the BEP in a tone-detection task might affect the level of masked thresholds, as listeners are hearing two tones and have to distinguish between them. In the [Sondhi and Guttman \(1966\)](#) study, the transitions in the masker from N_{π} to N_0 and back to N_{π} created two BEPs, which could have affected listeners' judgments. In their paper, [Sondhi and Guttman \(1966\)](#) recognized the presence of a "noise artifact" when the inner band of their stimulus was narrow. They attempted to ameliorate the impact of the artifact by pulsing the signal at 2 Hz, the intention being to allow the listener to distinguish the signal from the artifact. BEPs were also present in the stepwise and rectangular designs of the experiments conducted by [Holube et al. \(1998\)](#) at the transitions in the masker between N_0 and N_{π} configurations. The presence of these potentially confusing tonal percepts close in frequency to the tonal signal may have had unpredictable effects on the resulting pattern of data, undermining its interpretation in terms of filter bandwidth. In particular, it could be claimed the apparent breadth of binaural filters is somehow exaggerated by this artifact.

A single BEP was present in the stimuli presented by [Kohlrausch \(1988\)](#), at the transition at 500 Hz from in-phase to out-of-phase masking noise, but a further potential problem with the stimuli employed by [Kohlrausch \(1988\)](#) was that they provided listeners with the possibility of using an off-frequency listening strategy ([Patterson, 1976](#)). If the listener is able to use a range of filters with signal frequencies close to that of the signal, a better signal-to-noise ratio may be found by listening to a filter centered just above or below the signal frequency, thus producing lower thresholds and narrower filter bandwidth estimates ([Patterson, 1976](#)). As the fitting procedure did not explicitly model off-frequency listening, the procedure used by [Kohlrausch \(1988\)](#) may have underestimated the ERB. Off-frequency listening was more limited in the [Sondhi and Guttman \(1966\)](#) study, because attending to a filter slightly lower or higher in frequency than the signal would not have resulted in a substantially higher proportion of N_0 noise in the filter; interfering noise was present at both higher and lower frequencies in the spectrum.

The present experiment implemented a design similar to the $N_{\pi}S_{\pi}$ condition of [Sondhi and Guttman \(1966\)](#) and the rectangular condition of [Holube et al. \(1998\)](#), but adding two novel developments (see Fig. 3, left panels). First, in one condition, N_{π} interfering noise was used in the $N_{\pi}S_{\pi}$ configuration, but, in a second condition, the N_{π} sections of the masker were replaced with interaurally uncorrelated noise (N_u) in order to remove the BEP pitches from the stimulus. This configuration was thus $N_{u0\pi}S_{\pi}$. Both conditions with N_u and N_{π} interfering noise were employed as the use of the different interfering noises has distinct tradeoffs, namely, the salience of the binaural edge pitches and the size of BMLD. By replacing the outer N_{π} bands of the masker with N_u noise, the BEP pitches are replaced by "binaural-coherence-edge pitches" (BICEPs) ([Hartmann, 1984](#); [Hartmann and McMil-](#)

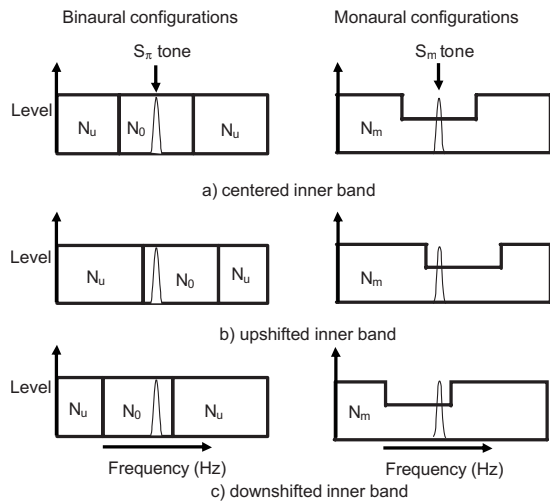

FIG. 3. Schematic illustration of the stimulus used in the current experiment in the N_u interfering noise condition (left panels) and monaural condition (right panels). The left panels depict the $N_{u0}S_\pi$ configuration, where the interaural phase relation of the masking noise is changed from uncorrelated to correlated, and back to uncorrelated as frequency increases. The right panels depict the N_mS_m monaural configuration, where the masker level is lowered by 15 dB in both ears, over the frequency range of the inner band. Panels (a), (b), and (c) show inner band centered, upshifted, and downshifted frequency ranges, respectively.

lon, 2001). The BICEP is a less salient dichotic pitch compared to the BEP (Akeroyd *et al.*, 2001), and occurs at points in the stimulus where in-phase and uncorrelated noises are juxtaposed due to the abrupt change in interaural phase from 0 rad to a random value. However, although the use of an N_u masker ameliorates the effects of any confounds due to dichotic pitches, a disadvantage of this stimulus configuration is that the maximum masked level difference is reduced; N_uS_π vs N_0S_π produces a maximum BMLD of 10–12 dB, while $N_\pi S_\pi$ vs N_0S_π gives a maximum BMLD of approximately 12–15 dB (Robinson and Jeffress, 1963).

The second development was to employ asymmetric placement of the signal frequency within the inner band in order to measure filter asymmetry. Asymmetry measurements of this sort are standard for measurements of filter shape in monaural experiments, but have not previously been used in binaural filter measurements. Both Sondhi and Guttman (1966) and Holube *et al.* (1998) used signals spectrally centered within the inner band of noise. In the present experiments, however, thresholds were measured for inner bands with centered, upshifted, and downshifted frequency ranges, in which the spectral position of the inner band was manipulated with respect to the tone [panels (a), (b), and (c) of Fig. 3, respectively].

Finally, binaural auditory filters were measured at signal frequencies of 250, 500, and 750 Hz, in order to examine how the ERB changed with signal frequency. It also allowed us to compare the results to previous experiments that have examined binaural filter bandwidths at different frequencies (Sondhi and Guttman, 1966, at 250 and 500 Hz; Kohlrausch, 1988, at 500 Hz; Holube *et al.*, 1998, at 500 Hz).

Monaural filters were measured using a similar procedure in order to compare monaural and binaural filters in the same group of listeners. In the monaural condition, the

masker level was attenuated by 15 dB over the frequency range of the inner band in order to roughly align the range of the data from the monaural and binaural stimuli. Figure 3 (right panels) illustrates the N_mS_m monaural configuration.

A. Stimuli and procedure

Three participants (including the first author) took part in the experiment. All were previously trained in psychophysical experiments and had no evidence or history of hearing impairment. Participants were aged between 18 and 25 years, one was male and two were female. Participants (excluding the author) were paid upon completion.

The stimuli were freshly generated digitally for each trial with a sampling rate of 44.1 kHz and 16-bit sample depth using MATLAB. A 500-ms sinusoidal signal was generated and shaped with a 20-ms raised cosine onset/offset ramp. In the monaural condition the signal was presented to the left ear only. In the binaural conditions, an inverted copy of the signal was simultaneously presented to the right ear. For each masking stimulus, 500-ms samples of Gaussian noise were generated. These noise samples were filtered in the frequency domain by scaling or zeroing appropriate Fourier components. All components above 3 kHz were zeroed. Inner and outer bands were prepared by creating complementary bandpass and bandstop noises and adding them together in appropriate combinations. N_u was produced using independent noise samples for each channel, while N_π was created by inverting the time waveform for one channel. For the monaural masking stimuli N_m , the left channel was filled with a notched noise. The notch was 15 dB deep, created by scaling the Fourier components within the inner band. A 10-ms raised cosine onset/offset ramp was applied to the time waveforms of the noise.

Digital-to-analog conversion was performed by a 24-bit Edirol UA-20 sound card. The stimuli were amplified by an MTR HPA-2 headphone amplifier and presented over Sennheiser HD650 headphones in a single-walled Industrial Acoustics Company sound-attenuating booth within a sound-deadened room. When the inner band bandwidth was zero the masker had an overall sound level of 75 dB (A).

Participants performed 2-interval, 2-alternative, forced choice (2I-2AFC) tasks. The order of target and non-signal interval was randomized for each trial, and trial-by-trial feedback was provided. Thresholds were measured for inner band bandwidths of 0, 71, 141, 200, and 283 Hz at a signal frequency of 250 Hz, and 0, 100, 141, 200, 283, and 400 Hz were tested at signal frequencies of 500 and 750 Hz. The following equations were used to calculate the low-pass cut-off frequency (l), and the high-pass cut-off frequency (h) of the inner band. f_s is the signal frequency, B is the bandwidth of the inner band, and r is the frequency of the signal with respect to the inner band, expressed as a percentage of the width of the band. r was either 50, 25, or 75, corresponding to the centered, upshifted, and downshifted frequency ranges [Fig. 3, panels (a), (b), and (c), respectively].

$$l = f_s - B \left(\frac{r}{100} \right), \quad (1)$$

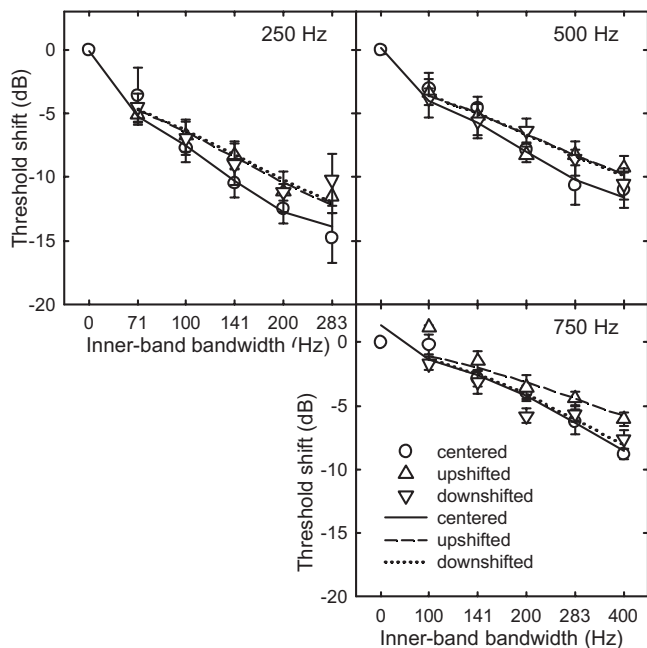

FIG. 4. Mean threshold binaural data with N_π interfering noise at signal frequencies of 250, 500, and 750 Hz (note that scaling of the x-axis varies with signal frequency). Threshold shift describes the BMLD, where 0 dB is the reference threshold obtained when the bandwidth of the inner band is 0 Hz. Open circles indicate thresholds for the centered frequency range, upwards pointing open triangles show thresholds obtained for the upshifted frequency range, and downwards pointing open triangles show thresholds for the downshifted range. Fitted thresholds (lines) are mean predicted thresholds from simple roex filters fitted to each individual listener. The x-axis is plotted logarithmically. Error bars are one standard error ($n=3$).

$$h = f_s + B \left(1 - \frac{r}{100} \right). \quad (2)$$

The listener's task was to identify the sound interval containing the tone. The level of the tone was varied adaptively in order to obtain a 70.7% correct estimate, using a "one-up/two-down" rule (Levitt, 1971). The initial level of the tone was chosen after pilot testing in order to be clearly audible for the first steps of the adaptive track. Initially, the step size of the adaptive track was set to 4 dB, and was reduced to 2 dB following two reversals. The last ten reversals comprised the measurement phase, and the average of the reversals within the measurement phase was taken as threshold. If the listener made a reversal within the first ten trials, data from the run were excluded and the run repeated.² After the stimuli were presented, listeners were presented with a MATLAB figure with two buttons corresponding to the two sound intervals, which allowed them to respond with the mouse. Thresholds were taken sequentially at each inner band bandwidth from 0 to 400 Hz at signal frequencies of 500 and 750 Hz, and from 0 to 283 Hz at a signal frequency of 250 Hz. The experiment was arranged in blocks so that participants finished providing thresholds at a signal frequency of 500 Hz before taking part in the 750 and 250 Hz signal frequency conditions. In order to familiarize the participants with the procedure, each performed a single trial at a signal frequency of 500 Hz with an inner band bandwidth of 0 Hz. Following familiarization, each participant provided thresholds for three conditions (N_m , N_π , and N_u interferers) \times (5 bandwidths

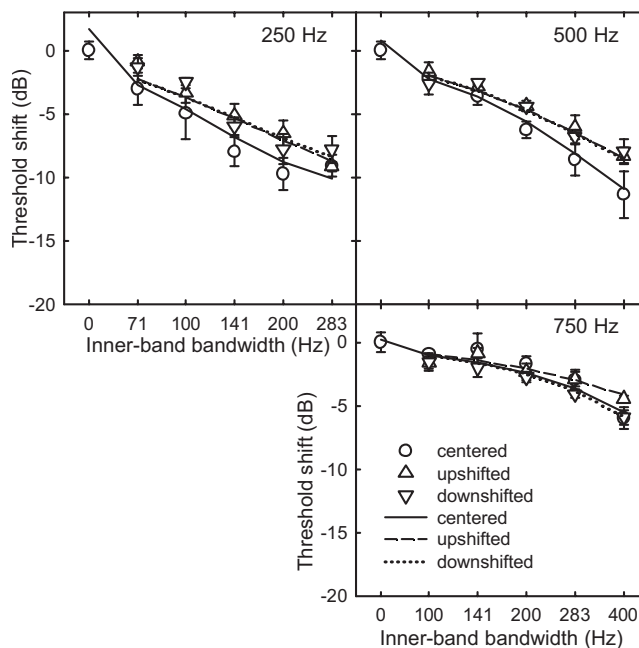

FIG. 5. As for Fig. 4, but for data with N_u interfering noise.

$\times 3$ frequency ranges + 1 bandwidth of zero) = 48 conditions. There were 3 repetitions of each condition, making 144 thresholds in all. The three repetitions of each condition were averaged to produce a final estimate.

B. Results

Figure 4–6 show mean thresholds (symbols), averaged across the three listeners, obtained with N_π , N_u , and N_m interfering noise, respectively. Each figure shows data at signal frequencies of 250, 500, and 750 Hz as a function of each inner band bandwidth for the three inner band frequency ranges (downshifted, centered, and upshifted). For N_π , at an

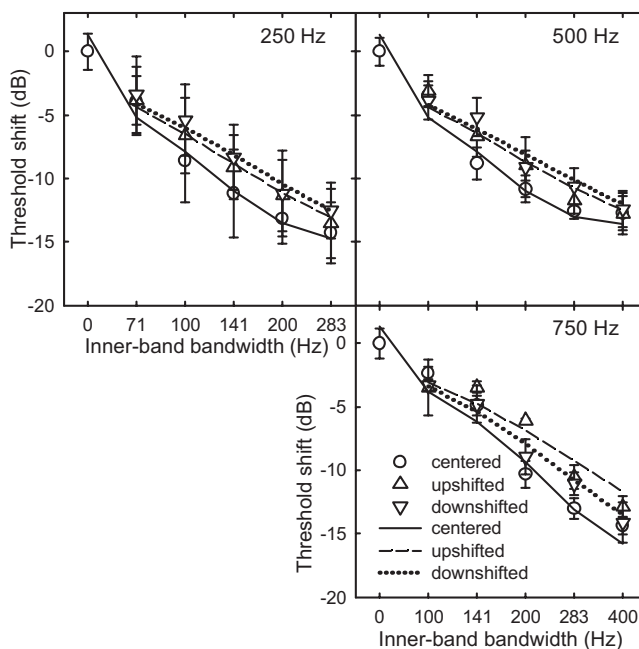

FIG. 6. As for Fig. 4, but for monaural data.

TABLE I. Simple roex binaural filter parameters obtained with N_π interfering noise for individual participants for each of the three signal frequencies. p_l is the parameter that describes the lower frequency slope of the filter peak, and p_u describes the higher frequency slope. The ERB is the integral divided by the peak gain in hertz of the entire filter.

| Listener | Signal frequency (Hz) | p_l (Hz) | p_u (Hz) | ERB (Hz) |
|----------|-----------------------|------------|------------|----------|
| AK | 250 | 39 | 39 | 78 |
| | 500 | 60 | 57 | 117 |
| | 750 | 123 | 85 | 208 |
| LD | 250 | 30 | 44 | 75 |
| | 500 | 53 | 69 | 121 |
| | 750 | 93 | 64 | 157 |
| RH | 250 | 35 | 28 | 63 |
| | 500 | 67 | 54 | 121 |
| | 750 | 108 | 59 | 167 |

inner band bandwidth of zero, thresholds were 48.4, 49.0, and 49.5 dB (A) at signal frequencies of 250, 500, and 750 Hz, respectively. For N_u they were approximately 2 dB lower at 45.6, 47.3, and 48.3 dB (A). For N_m they were 1.2 dB higher at 51.0, 48.5, and 51.0 dB (A). In all cases, thresholds fell as inner band bandwidth increased. In most cases, lowest thresholds were obtained for the centered inner band, and overall improvement for the other frequency ranges was less than for the centered frequency range. These effects all reflect filter bandwidth in one way or another, but are difficult to interpret by visual inspection.

Simple asymmetric rounded-exponential (roex) filters (as applied by Culling and Summerfield, 1998) were fitted to the data. Fitted thresholds (lines) were plotted by averaging individually fitted thresholds across participants. The filter parameters for N_π , N_u , and N_m are shown in Tables I–III, respectively. The average resulting filter shapes are plotted in Fig. 7. The ERB of the filter was found to increase with signal frequency. When plotted on a log-log scale, the filters were asymmetric with shallower lower slopes than upper slopes. In all cases the ERB of filter was found to increase with signal frequency, but the filter bandwidths for the N_u

TABLE II. As for Table II, but for simple roex binaural fits obtained with N_u interfering noise for individual participants for each of the three signal frequencies.

| Listener | Signal frequency (Hz) | p_l (Hz) | p_u (Hz) | ERB (Hz) |
|----------|-----------------------|------------|------------|----------|
| AK | 250 | 47 | 48 | 95 |
| | 500 | 78 | 77 | 155 |
| | 750 | 280 | 162 | 442 |
| LD | 250 | 52 | 62 | 114 |
| | 500 | 84 | 84 | 168 |
| | 750 | 206 | 106 | 313 |
| RH | 250 | 28 | 26 | 55 |
| | 500 | 79 | 77 | 157 |
| | 750 | 292 | 106 | 399 |

TABLE III. As for Table II, but for simple roex monaural fits for individual participants, for each of the three signal frequencies.

| Listener | Signal frequency (Hz) | p_l (Hz) | p_u (Hz) | ERB (Hz) |
|----------|-----------------------|------------|------------|----------|
| AK | 250 | 32 | 32 | 64 |
| | 500 | 40 | 46 | 86 |
| | 750 | 59 | 43 | 102 |
| LD | 250 | 39 | 44 | 83 |
| | 500 | 39 | 46 | 84 |
| | 750 | 54 | 57 | 111 |
| RH | 250 | 22 | 27 | 49 |
| | 500 | 43 | 40 | 83 |
| | 750 | 65 | 45 | 110 |

interferer tended to be larger than for the N_π case, especially at a signal frequency of 750 Hz (compare top and middle panels of Fig. 7), and the ERBs of the monaural filters were markedly smaller (bottom panel).

Table IV shows a summary of monaural and binaural filter fits from a range of studies using, wherever possible, the same type of fitted filter shape. Simple roex filter fits from the current study are given the table, which shows that binaural roex fits at all signal frequencies are wider than monaural measurements at corresponding signal frequencies from all studies.

A within-subjects analysis of variance (ANOVA) conducted on the ERB values derived from fits to the present data showed significant main effects of condition ($F(2,4) = 114.7, p < 0.001$), and signal frequency ($F(2,4) = 37.5, p < 0.005$), and a significant interaction between condition and signal frequency ($F(2,8) = 25.5, p < 0.001$). Pairwise comparisons with a Bonferroni correction ($\alpha = 0.017$) showed a

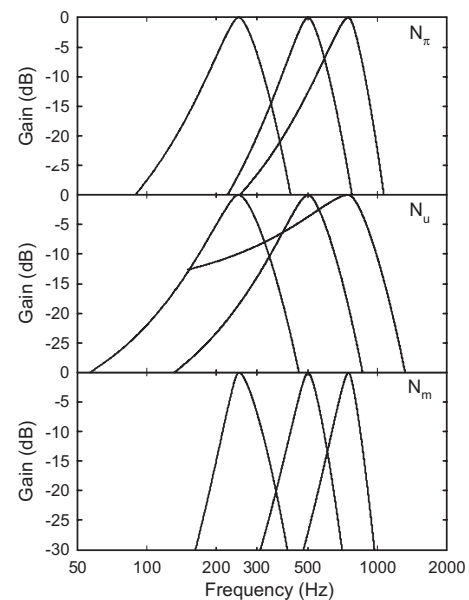

FIG. 7. Attenuation characteristics of binaural filters measured using N_π , N_u , and monaural interfering noise averaged across individual listeners at signal frequencies of 250, 500, and 750 Hz. The frequency axis is plotted logarithmically.

TABLE IV. Auditory filter bandwidth (Hz) data from a range of studies. All fits assume a simple roex shape. There is one exception in the table; the signal frequency of the Moore *et al.* (1990) study was 800 Hz. ERB values from Glasberg and Moore (1990) were calculated from Eq. 3 of their study. Mean ERB values across listeners at each signal frequency from the current study are given. N_u specifies that the study implemented interaurally uncorrelated interfering noise, and N_π that anticorrelated interfering noise was used.

| Study | Type | Signal frequency (Hz) | | |
|----------------------------|-------------------|-----------------------|-----|-----|
| | | 250 | 500 | 750 |
| Glasberg and Moore (1990) | Monaural | 52 | 79 | 106 |
| Moore <i>et al.</i> (1990) | Monaural | ... | ... | 147 |
| Current study | Monaural | 65 | 84 | 108 |
| | Binaural: N_u | 88 | 160 | 385 |
| | Binaural: N_π | 72 | 120 | 177 |

significant difference between each of the binaural conditions (N_π and N_u) and the monaural condition (N_m). No difference was observed between the two binaural conditions ($p=0.02$).

III. GENERAL DISCUSSION

A. Comparison of monaural and binaural filter bandwidth

In Figs. 4 and 5 little or no binaural unmasking occurs when the bandwidth of the inner band is zero (equivalent to an $N_\pi S_\pi$ configuration in Fig. 4 and an $N_u S_\pi$ configuration in Fig. 5). As the inner band bandwidth increases, thresholds at all three inner band frequency ranges decrease as more N_0 noise enters the filter, leading to greater unmasking. Thresholds are presumably lowest for the centered inner band frequency range because the filters are roughly symmetric and the tone is at the center of a filter which captures a minimum of interfering noise. The magnitude of the overall BMLD tends to fall as signal frequency is increased, because the BMLD is greatest for the frequency region around 200 Hz, and decreases as signal frequency is increased (Hirsh and Burgeat, 1958). Smaller BMLDs were observed when an N_u interferer was employed compared to thresholds obtained with an N_π interferer, consistent with Robinson and Jeffress (1963). Differences between these data and those for the monaural condition (Fig. 6) are not obvious. The interpretation of the data in terms of filter shape relies on the filter fitting process (see the Appendix).

The fitted binaural filter bandwidths were found to increase with signal frequency, and to be wider than comparable monaural bandwidths. On a logarithmic frequency axis, the asymmetry of the filters increases with signal frequency, where the upper slope tends to be steeper than the lower slope (see Fig. 7), an observation also to be found in measurements of the monaural filter (e.g., Moore *et al.*, 1990) although less pronounced for the monaural fits in the current study.

The binaural bandwidths measured in the current study were as wide as or wider than previous measurements in literature (Table IV). The monaural bandwidths obtained in

the current study were comparable to the estimates made by Glasberg and Moore (1990), and lower than Moore *et al.* (1990). At 250 and 500 Hz, binaural filters measured using an N_u interferer were found to be significantly wider than corresponding monaural filters measured for the same participants (by factors of 1.25 and 1.9). Binaural filters measured at the same frequencies using an N_π interferer were wider by factors of only 1.11 and 1.43. The latter estimate is consistent with the findings of Holube *et al.* (1998), who obtained binaural filters wider than monaural filters by a factor of 1.2 using a similar experimental design and noise type. The fact that filters appeared broader using the novel N_u interferer than when using an N_π interferer, which produces BEPs, suggests that the presence of BEPs in the stimuli used by Sondhi and Guttman (1966) and by Holube *et al.* (1998) was not responsible for the observation of broader auditory filters than found for monaural stimuli. Nonetheless, the variation in results across methods suggests that further effort to refine and understand our measurement techniques will be necessary.

B. Why are the binaural filters wider?

Though the findings of a number of studies indicate that binaural auditory filters are wider than their monaural counterparts, this interpretation has been challenged. It was suggested by van de Par and Kohlrausch (1999) that the binaural system attends to one or more auditory filters depending on which arrangement results in optimal detection. They argued that binaural processing is constrained by the same peripheral processes as in the monaural case, but that binaural processing is influenced by a wider range of frequencies that includes information from filters adjacent to the filter centered at the signal frequency, leading to a wider operational bandwidth depending on whether the masker is narrowband or broadband (Bernstein *et al.*, 2006).

For tones in narrowband noise, it was reasoned that both central and adjacent filters provide binaural information that can be combined for signal detection, improving the detection threshold given that the internal noise of each filter is independent. Combining binaural information from several filters reduces the internal noise compared to using only the central filter, while not introducing any additional masking noise. However, for tones in broadband noise, only the central filter provides useful binaural information, because adjacent filters are excited by additional masking noise.

van de Par and Kohlrausch (1999) reasoned that when Kohlrausch (1988) measured binaural frequency selectivity using broadband masking noise with a frequency dependent correlation, only a single auditory filter centered at the signal frequency provided information for the binaural processor. Other filters made a negligible contribution because they were excited by additional masking noise. This account can explain why the binaural filter measured by Kohlrausch (1988) had an ERB comparable to that of the monaural filter, providing support to the notion that binaural frequency selectivity is the same as monaural frequency selectivity.

It was stated by van de Par and Kohlrausch (1999) that their argument could be applied to all experiments that use

analogs of the notched-noise technique, a tonal signal and broadband masking noise. However, the experiments of [Sondhi and Guttman \(1966\)](#), [Holube et al. \(1998\)](#), and the present experiment all fall into this category. Because the notched-noise technique utilizes broadband masking noise across the spectrum, independent of the specific condition, only the filter centered at the test frequency provides useful binaural information and combining information across filters should reduce sensitivity. The results of [Sondhi and Guttman \(1966\)](#), [Holube et al. \(1998\)](#), and the present study thus suggests that the binaural auditory filter is wider than its monaural counterpart, rather than manifesting itself as a wider operational binaural bandwidth stemming from across-frequency integration of monaural filters.

Another possibility is that wider binaural filters somehow stem from a mismatch between left and right ear channels. In that case, the measurements made here may reflect the mean shape of the region of overlap between the frequency responses of the two peripheral filters involved. Since the overlap of mismatched filters is likely to occur away from their peak sensitivity, the wide skirts of the monaural filters may provide the origin of the wide binaural filters. Some models of the processing of interaural time delay rely on the existence of such mismatches. [Schroeder \(1977\)](#) suggested that mismatches could provide an alternative to [Jeffress' \(1948\)](#) account of interaural time delay (ITD) sensitivity, based on axonal propagation delay (see also [Bonham and Lewis, 1999](#) and [Magezi and Krumbholz, 2008](#)). In [Jeffress' \(1948\)](#) model differential axonal transmission time creates a compensating delay to the external ITD, allowing action potentials with a particular ITD to arrive simultaneously at a specific central coincidence detecting neuron. Excitation of that neuron would thus code the presence of sound with a particular ITD. A cross-channel model of ITD processing, on the other hand, exploits phase differences between non-corresponding frequency channels that are generated by the cochlear traveling wave.

C. Implications of wider binaural filters

Assuming that the [Jeffress' \(1948\)](#) model is an accurate representation of binaural detection performance, quantifying the binaural filter bandwidth is useful for judging the range of internal delays available to the binaural system (e.g., [Langford and Jeffress, 1964](#); [Rabiner et al., 1966](#)). The filter is important because both the range of internal delays available and the width of the auditory filter influence the size of the BMLD as a function of noise delay; BMLDs occurring at very long noise delays can be explained either by the existence of very long delay lines or by very narrow filters. If the width of the auditory filter is known, the range of delays available can be inferred from this noise delay function. The wider the filter, the greater the inferred range of internal delays must be. Findings such as those of the current study, that binaural filters are relatively broad, imply the existence of longer rather than shorter delay lines.

Binaural unmasking assists not only in the detection of tones, but also the understanding of speech in background noise ([Licklider, 1948](#)). Speech information is delivered

through its complex spectrotemporal pattern. In order for the binaural system to contribute to speech understanding, it seems reasonable to suppose that it must encode this spectrotemporal pattern, so limitations in the spectral and temporal resolution of the binaural system may be expected to affect binaural unmasking for speech. [Culling and Colburn \(2000\)](#) have previously shown that unmasking effects for both the discrimination of tone sequences and the understanding of speech are reduced when the rate of presentation is increased. This effect may be attributed to binaural sluggishness, which temporally smears the internal representation of very rapid sound sequences recovered by the binaural system. Spectral smearing of this representation may also have some effect. It has been argued that reduced frequency selectivity plays a role in hearing impairment, leading to difficulty understanding speech in the presence of background noise ([Plomp, 1994](#); [Moore, 1998](#)). A number of studies have examined speech intelligibility in background noise within this framework. [Baer and Moore \(1993\)](#) used a spectral smearing technique to simulate the effects of broadened auditory filters in hearing-impaired listeners. The results indicated that spectral smearing had little effect on speech intelligibility in quiet listening conditions, but a large effect on speech intelligibility in noise. A similar study of speech intelligibility in the presence of a single interfering talker demonstrated similar results ([Baer and Moore, 1994](#)), and was in agreement with a study by [ter Keurs et al. \(1993\)](#) that also examined the effects of spectral smearing on speech intelligibility. Those results indicate that high spectral resolution is important in speech segregation tasks. The present study implies that speech information recovered by the binaural system will have relatively low spectral resolution, which may have some measurable effect on its usefulness.

Finally, when rapid sequences of sound are heard, sounds with components in a similar range of frequencies tend to be grouped together, a phenomenon called fusion or coherence where the sounds are perceived to originate from a single source. Sounds with components in different frequency ranges tend to be heard as different streams, originating from different sources, a phenomenon called fission or segregation ([Van Noorden, 1975](#)). When successive tones, separated in frequency, are presented to listeners and the frequency separation is less than a critical value called the fission boundary, a single stream is heard. This is distinct from the temporal coherence boundary, which is the value of frequency separation above which two streams are heard. Research has provided support to the proposition that the percept of one or more streams is at least partly dependent on the overlap of the excitation patterns evoked by sounds in the cochlea ([Rose and Moore, 1997](#)), where the overlap of the excitation patterns depends on the sharpness of the auditory filters ([Moore and Glasberg, 1983, 1987](#)). The frequency difference between successive tones at the fission boundary was found to significantly increase with increasing level, consistent with the broadening of monaural auditory filters with increasing level ([Rose and Moore, 2000](#)). Since [Akeroyd et al. \(2005\)](#) has demonstrated that streaming occurs for Huggins pitches (pitch percepts that are only derived binaurally), the fission boundary may differ between a monaural condi-

tion consisting of partially masked tones-in-noise, and a dichotic condition where streams are evoked by Huggins pitches. Comparison of the fission boundary between monaural and dichotic conditions could provide a method of confirming the findings of the current study; if the binaural auditory filter is wider than the monaural auditory filter, then the fission boundary would be wider for Huggins pitch stimuli than for partially masked tones-in-noise, and this reasoning would extend to other dichotic pitches, including the BEP and BICEP.

IV. CONCLUSIONS

The data and modeling described in this paper support the following conclusions concerning the binaural auditory filter.

- (1) The ERB estimates of binaural filters are larger than comparable monaural filters, but share a similar asymmetry.
- (2) Previous findings to this effect were not confounded by the presence of dichotic pitches in the masking stimulus.
- (3) The ERB of the binaural auditory filter increases with signal frequency in parallel with the monaural filter.

ACKNOWLEDGMENTS

The work was supported by a studentship from the EPSRC. A summary of these findings was presented at the September 2006 BSA meeting. We would like to extend our thanks to three anonymous reviewers for their helpful comments regarding previous drafts of this manuscript, and to Joni Karanka for insightful discussion of the experiments.

APPENDIX: FILTER FITTING

The auditory filter fitting procedure was similar to that used by [Patterson and Nimmo-Smith \(1980\)](#) and [Moore et al. \(1990\)](#) to measure monaural auditory filters. In this technique, the shape of the auditory filter is defined by a number of parameters. These parameters are fitted to the empirical data using a multi-dimensional, least-squares parameter estimation, combined with a model of masking. The technique was adapted to the analysis of binaural data by adopting the assumption that the diotic portion of the noise entering a given frequency channel can largely be canceled by the binaural system, resulting in a reduced effective level of masking noise within that channel. Identical fitting procedures could then be applied to monaural and binaural data. Off-frequency listening is modeled by assuming that the listener always uses the filter that provides the best effective signal-to-noise ratio. Off-frequency listening does not therefore involve an additional parameter in the filter fit; if it did, the model could assume sub-optimal off-frequency listening in order to better fit the data.

For monaural filters, a power-spectrum model of masking was used to predict thresholds for a given filter. This model was similar to that of [Patterson and Nimmo-Smith \(1980\)](#) except that our model accommodated the fact that our notches contained some masking noise at a lower spectrum level than the surrounding noise. For binaural auditory fil-

ters, it was assumed that a fixed proportion of the interaurally correlated noise within the filter channel would be canceled by the binaural system, reducing the effective noise level in the “notch” by a fixed number of decibels. This assumption is consistent with the well-established relationship between interaural masker correlation and masked threshold ([Robinson and Jeffress, 1963](#)). Interaural correlation is the proportion (in terms of power) of interaurally correlated noise, and [van der Heijden and Trahiotis \(1997\)](#) have shown the relationship between masked threshold in linear units of power and interaural masker correlation is linear. Thus, unmasking is directly related to the proportion of interaurally correlated noise power, as though any interaurally correlated noise has largely been removed. Equalization-cancellation theory ([Durlach, 1972](#)) also predicts [Robinson and Jeffress’ \(1963\)](#) data on this basis. The depth of effective notch at each frequency, for each listener and for each type of interfering noise, was a free parameter in the fitting process for each fitted filter shape, constrained only to be less than or equal to 15 dB.

The filter parameters were freely adjusted by the SIMPLEX method ([Nedler and Mead, 1965](#)) to obtain the filter parameters that produced the best fit to the data, defined as that providing the minimum squared discrepancy with the empirical data. Off-frequency listening was explicitly modeled using a single-parameter minimization method to position a candidate filter in frequency so as to maximize effective signal-to-noise ratio in the filter. Predicted thresholds were the inverse of these optimized signal-to-noise ratios. The difference between the mean of the ensemble of predictions for a given candidate window and the mean of the corresponding measured thresholds was subtracted from the predicted values before the squared error was calculated.

The roex (rounded-exponential) equation was used for all filter fits. It describes the slope of the frequency response $G(f)$ on one side of the filter as a function of frequency f , where $f=0$ at the center frequency of the filter. The parameter p determines the slope of the function. Asymmetry in the filter was modeled by substituting the parameters p_l and p_u , where p_l is the parameter that describes the lower frequency slope of the filter, and p_u describes the upper frequency slope. The ERB is the sum of p_l and p_u .

Signal gain was determined using the equation for the rounded exponential

$$G(f) = (1 + 2f/p)e^{-2f/p}. \quad (A1)$$

This gain would be reduced from unity, where off-frequency listening is used. Noise in each half of the filter was determined by the definite integral

$$\int_0^f (1 + 2f/p)e^{-2f/p} df = p - (p + f)e^{-2f/p}. \quad (A2)$$

¹[Holube et al. \(1998\)](#) fitted existing data from literature with binaural filters by calculating the effective correlation within the binaural filter for each datapoint on the basis of the formulas from equalization-cancellation (EC) theory ([Durlach, 1972](#)). They reported that the experimental data of [Kohlrausch \(1988\)](#) could not be fitted because the probe tone frequency was not fixed at 500 Hz, but was varied throughout the experiment. The values of binaural filter bandwidth from [Kohlrausch’s \(1988\)](#) study were higher than

those obtained by Holube *et al.* (1998), which Holube *et al.* attributed to Kohlrausch's use of a trapezoidal filter in the fitting procedure, whereas Holube *et al.* assumed a double-exponential filter which is triangular on a decibel scale. Kollmeier and Holube (1992) conducted a study with a similar design to Kohlrausch (1988) with a fixed probe tone at 500 Hz, in which the transition frequency of the masker from in-phase to out-of-phase was varied. Double exponential fits ranged from 56 to 77 Hz, which were lower than the 80–84 Hz filter bandwidths reported by Kohlrausch (1988).

²A reversal made early on in an adaptive track can have a disproportionate effect on the final threshold, as the step size is reduced after the first reversal, making it harder for the listener to obtain a low threshold. Ten trials was chosen as a cut-off point because the tone is clearly audible in the first ten trials in each condition; thus any reversal is almost certainly attributable to the listener accidentally clicking the wrong response button.

- Akeroyd, M. A., Carlyon, R. P., and Deeks, J. M. (2005). "Can dichotic pitches form two streams?," *J. Acoust. Soc. Am.* **118**, 977–981.
- Akeroyd, M. A., Moore, B. C. J., and Moore, G. A. (2001). "Melody recognition using three different types of dichotic-pitch stimulus," *J. Acoust. Soc. Am.* **110**, 1498–1504.
- Baer, T., and Moore, B. C. J. (1993). "Effects of spectral smearing on the intelligibility of sentences in the presence of noise," *J. Acoust. Soc. Am.* **94**, 1229–1241.
- Baer, T., and Moore, B. C. J. (1994). "Effects of spectral smearing on the intelligibility of sentences in the presence of interfering speech," *J. Acoust. Soc. Am.* **95**, 2277–2280.
- Baker, R. J., and Rosen, S. (2006). "Auditory filter nonlinearity across frequency using simultaneous notched-noise masking," *J. Acoust. Soc. Am.* **119**, 454–462.
- Bernstein, L. R., Trahiotis, C., and Freyman, R. L. (2006). "Binaural detection of 500-Hz tones in broadband and in narrowband masking noise: Effects of signal/masker duration and forward masking fringes," *J. Acoust. Soc. Am.* **119**, 2981–2993.
- Bonham, B. H., and Lewis, E. R. (1999). "Localization by interaural time difference (ITD): Effects of interaural frequency mismatch," *J. Acoust. Soc. Am.* **106**, 281–290.
- Cramer, E. M., and Huggins, W. H. (1958). "Creation of pitch through binaural interaction," *J. Acoust. Soc. Am.* **30**, 413–417.
- Culling, J. F., and Colburn, H. S. (2000). "Binaural sluggishness in the perception of tone sequences and speech in noise," *J. Acoust. Soc. Am.* **107**, 517–527.
- Culling, J. F., and Summerfield, Q. (1998). "Measurement of the binaural temporal window using a detection task," *J. Acoust. Soc. Am.* **103**, 3540–3553.
- Durlach, N. I. (1972). "Binaural signal detection: Equalization and cancellation theory," in *Foundations of Modern Auditory Theory*, edited by J. V. Tobias (Academic, New York), Vol. **II**, pp. 369–462.
- Fletcher, H. (1940). "Auditory patterns," *Rev. Mod. Phys.* **12**, 47–65.
- Glasberg, B. R., and Moore, B. C. J. (1990). "Derivation of auditory filter shapes from notched-noise data," *Hear. Res.* **47**, 103–138.
- Glasberg, B. R., and Moore, B. C. J. (2000). "Frequency selectivity as a function of level and frequency measured with uniformly exciting notched noise," *J. Acoust. Soc. Am.* **108**, 2318–2328.
- Hartmann, W. M. (1984). "Binaural coherence edge pitch," *J. Acoust. Soc. Am.* **75**, S22.
- Hartmann, W. M., and McMillon, C. D. (2001). "Binaural coherence edge pitch," *J. Acoust. Soc. Am.* **109**, 294–305.
- Hirsh, I. J., and Burgeat, M. (1958). "Binaural effects is remote masking," *J. Acoust. Soc. Am.* **30**, 827–832.
- Holube, I., Kinkel, M., and Kollmeier, B. (1998). "Binaural and monaural auditory filter bandwidths and time constants in probe tone detection experiments," *J. Acoust. Soc. Am.* **104**, 2412–2425.
- Jeffress, L. A. (1948). "A place theory of sound localization," *J. Comp. Physiol. Psychol.* **41**, 35–39.
- Klein, M. A., and Hartmann, W. M. (1981). "Binaural edge pitch," *J. Acoust. Soc. Am.* **70**, 51–61.
- Kohlrausch, A. (1988). "Auditory filter shape derived from binaural masking experiments," *J. Acoust. Soc. Am.* **84**, 573–583.
- Kollmeier, B., and Holube, I. (1992). "Auditory filter bandwidths in binaural and monaural listening conditions," *J. Acoust. Soc. Am.* **92**, 1889–1901.
- Langford, T. L., and Jeffress, L. A. (1964). "Effect of noise crosscorrelation on binaural signal detection," *J. Acoust. Soc. Am.* **36**, 1455–1458.
- Levitt, H. (1971). "Transformed up-down methods in psychoacoustics," *J. Acoust. Soc. Am.* **49**, 467–477.
- Licklider, J. C. R. (1948). "The influence of interaural phase relations on the masking of speech by white noise," *J. Acoust. Soc. Am.* **20**, 150–159.
- Magezi, D. A., and Krumbholz, K. (2008). "Can the binaural system extract fine-structure interaural tone differences from noncorresponding frequency channels?," *J. Acoust. Soc. Am.* **124**, 3095–3107.
- Moore, B. C. J. (1998). *Cochlear Hearing Loss* (Whurr, London).
- Moore, B. C. J., and Glasberg, B. R. (1983). "Suggested formulae for calculating auditory-filter bandwidths and excitation patterns," *J. Acoust. Soc. Am.* **74**, 750–753.
- Moore, B. C. J., and Glasberg, B. R. (1987). "Formulae describing frequency selectivity as a function of frequency and level, and their use in calculating excitation patterns," *Hear. Res.* **28**, 209–225.
- Moore, B. C. J., Peters, R. W., and Glasberg, B. R. (1990). "Auditory filter shapes at low center frequencies," *J. Acoust. Soc. Am.* **88**, 132–140.
- Nedler, J. A., and Mead, R. (1965). "A simplex method for function minimization," *Comput. J.* **7**, 308–313.
- Patterson, R. D. (1974). "Auditory filter shape," *J. Acoust. Soc. Am.* **55**, 802–809.
- Patterson, R. D. (1976). "Auditory filter shapes derived with noise stimuli," *J. Acoust. Soc. Am.* **59**, 640–654.
- Patterson, R. D., and Nimmo-Smith, I. (1980). "Off-frequency listening and auditory-filter asymmetry," *J. Acoust. Soc. Am.* **67**, 229–245.
- Plomp, R. (1994). "Noise, amplification, and compression: Considerations of three main issues in hearing aid design," *Ear Hear.* **15**, 2–12.
- Rabiner, L. R., Laurence, C. L., and Durlach, N. I. (1966). "Further results on binaural unmasking and the EC model," *J. Acoust. Soc. Am.* **40**, 62–70.
- Robinson, D. E., and Jeffress, L. A. (1963). "Effect of varying the interaural noise correlation on the detectability of tonal signals," *J. Acoust. Soc. Am.* **35**, 1947–1952.
- Rose, M. M., and Moore, B. C. J. (1997). "Perceptual grouping of tone sequences by normally hearing and hearing-impaired listeners," *J. Acoust. Soc. Am.* **102**, 1768–1778.
- Rose, M. M., and Moore, B. C. J. (2000). "Effects of frequency and level on auditory stream segregation," *J. Acoust. Soc. Am.* **108**, 1209–1214.
- Schroeder, M. R. (1977). "New viewpoints in binaural interactions," in *Psychophysics and Physiology of Hearing*, edited by E. F. Evans and J. P. Wilson (Academic, New York), pp. 455–467.
- Sondhi, M. N., and Guttman, N. (1966). "Width of the spectrum effective in the binaural release of masking," *J. Acoust. Soc. Am.* **40**, 600–606.
- ter Keurs, M., Festen, J. M., and Plomp, R. (1993). "Effect of spectral envelope smearing on speech reception. II," *J. Acoust. Soc. Am.* **93**, 1547–1552.
- van de Par, S., and Kohlrausch, A. (1999). "Dependence of binaural masking level differences on center frequency, masker bandwidth, and interaural parameters," *J. Acoust. Soc. Am.* **106**, 1940–1947.
- van der Heijden, M. L., and Trahiotis, C. (1997). "A new way to account for binaural detection as a function of interaural noise correlation," *J. Acoust. Soc. Am.* **101**, 1019–1022.
- van der Heijden, M. L., and Trahiotis, C. (1998). "Binaural detection as a function of interaural correlation and bandwidth of masking noise: Implications for estimates of spectral resolution," *J. Acoust. Soc. Am.* **103**, 1609–1614.
- Van Noorden, L. P. A. S. (1975). "Temporal coherence in the perception of tone sequences," Ph.D. thesis, Eindhoven, The Netherlands.