

Online Research @ Cardiff

This is an Open Access document downloaded from ORCA, Cardiff University's institutional repository: <http://orca.cf.ac.uk/105124/>

This is the author's version of a work that was submitted to / accepted for publication.

Citation for final published version:

Knapper, Steven, Russell, Nigel, Gilkes, Amanda, Hills, Robert K., Gale, Rosemary E., Cavenagh, James D., Jones, Gail, Kjeldsen, Lars, Grunwald, Michael R., Thomas, Ian, Konig, Heiko, Levis, Mark J. and Burnett, Alan K. 2017. A randomized assessment of adding the kinase inhibitor lestaurtinib to first-line chemotherapy for FLT3-mutated AML. *Blood* 129 (9) , pp. 1143-1154. 10.1182/blood-2016-07-730648 file

Publishers page: <http://dx.doi.org/10.1182/blood-2016-07-730648> <<http://dx.doi.org/10.1182/blood-2016-07-730648>>

Please note:

Changes made as a result of publishing processes such as copy-editing, formatting and page numbers may not be reflected in this version. For the definitive version of this publication, please refer to the published source. You are advised to consult the publisher's version if you wish to cite this paper.

This version is being made available in accordance with publisher policies. See <http://orca.cf.ac.uk/policies.html> for usage policies. Copyright and moral rights for publications made available in ORCA are retained by the copyright holders.



A randomised assessment of adding the kinase inhibitor lestaurtinib to first-line chemotherapy for *FLT3*-mutated acute myeloid leukemia

Steven Knapper¹, Nigel Russell², Amanda Gilkes³, Robert K Hills⁴, Rosemary E Gale⁵, James D Cavenagh⁶, Gail Jones⁷, Lars Kjeldsen⁸, Michael R Grunwald⁹, Ian Thomas⁴, Heiko Konig¹⁰, Mark J Levis¹¹, Alan K Burnett¹

¹Department of Haematology, Cardiff University School of Medicine, Cardiff, UK;

²Department of Haematology, Nottingham University Hospital, Nottingham, UK;

³Experimental Cancer Medicine Centre, Cardiff University School of Medicine, Cardiff UK;

⁴Centre for Trials Research, College of Biomedical and Life Sciences, Cardiff University, Cardiff UK; ⁵Department of Haematology, University College London Cancer Institute, London, UK

⁶of Haematology, Bart's Health NHS Trust, London, UK; ⁷Department of Haematology, Newcastle-upon-Tyne Hospitals NHS Foundation Trust, Newcastle, UK;

⁸Department of Haematology, Rigshospitalet, Copenhagen, Denmark; ⁹Department of Hematologic Oncology and Blood Disorders, Levine Cancer Institute, Carolinas HealthCare System, Charlotte, NC; ¹⁰Indiana University Melvin and Bren Simon Cancer Center, Indianapolis, IN; ¹¹Division of Hematological Malignancies, Johns Hopkins Sidney Kimmel Cancer Centre, Baltimore, MD.

Short title for running head: Lestaurtinib in newly-diagnosed FLT3-mutated AML

Corresponding author:

Dr Steven Knapper, Division of Cancer & Genetics, School of Medicine, Cardiff University, Heath Park, Cardiff, CF14 4XN, United Kingdom

E-mail: knappers@cf.ac.uk

Telephone: 0044 2920 745379, Fax: 0044 2920 744655

Text word count: 3977

Abstract word count: 250

Number of figures: 5 (plus 3 Supplemental)

Number of tables: 2 (plus 2 Supplemental)

Number of references: 30

Scientific Category: Clinical Trials and Observations

Key Points

- No overall clinical benefit was seen following the addition of Lestaurtinib to standard chemotherapy for newly-diagnosed FLT3-mutated AML
- Lower rates of relapse and improved overall survival were seen in patients who achieved sustained levels of FLT3 inhibitory activity

Abstract

The clinical benefit of adding FLT3-directed small molecule therapy to standard first-line treatment of acute myeloid leukemia (AML) has not yet been established. As part of the UK AML15 and 17 trials, patients with previously-untreated AML and confirmed FLT3-activating mutations, mostly aged <60 years, were randomised to receive oral Lestaurtinib (CEP701), or not, following each of four cycles of induction and consolidation chemotherapy. Lestaurtinib was commenced 2 days after completing chemotherapy and administered in cycles of up to 28 days. The trials ran consecutively; primary endpoints were overall survival in AML15 and relapse-free survival in AML17; outcome data were meta-analysed. 500 patients were randomised between Lestaurtinib and control; 74% had *FLT3*-ITD mutations, 23% *FLT3*-TKD point mutations, 2% both types. No significant differences were seen in either 5-year overall survival (Lestaurtinib 46% vs control 45%, HR 0.90 [0.70-1.15], p=0.3) or 5-year relapse-free survival (40% vs 36%, HR 0.88 [0.69-1.12], p=0.3). Exploratory sub-group analysis suggested survival benefit with Lestaurtinib in patients receiving concomitant azole anti-fungal prophylaxis and gemtuzumab ozogamicin with the first course of chemotherapy. Correlative studies included analysis of in vivo FLT3 inhibition by plasma inhibitory activity assay and indicated improved overall survival and significantly reduced rates of relapse in Lestaurtinib-treated patients who achieved sustained >85% FLT3 inhibition. In conclusion, combining Lestaurtinib with intensive chemotherapy proved feasible in younger patients with newly-diagnosed *FLT3*-mutated AML but yielded no overall clinical benefit. The improved clinical outcomes seen in patients achieving sustained FLT3 inhibition encourage continued evaluation of FLT3-directed therapy alongside front-line AML treatment.

Introduction

Activating mutations of the receptor tyrosine kinase FMS-like tyrosine kinase-3 (FLT3) are present at diagnosis in approximately one-third of patients with acute myeloid leukemia (AML), the majority of whom have a normal karyotype (1-3). **Internal tandem duplication (ITD) mutations of the FLT3 juxtamembrane domain account for approximately three-quarters of these mutations and are associated with proliferative disease phenotype, increased relapse rate and shortened overall survival (OS)** (4-6). The prognostic implications of the FLT3-ITD mutation vary according to mutation burden, with a high allelic ratio predicting higher relapse risk (5), and according to presence of co-existing mutations; the most frequent of these being *NPM1c* which is present in 60% of younger FLT3-ITD mutated cases and appears to lessen the adverse prognostic impact (7). **Tyrosine kinase domain point mutations make up the remaining 25% of FLT3 mutations and have less clearly-established prognostic associations (8).**

Given the high incidence and clear deleterious prognostic impact of FLT3-ITD mutations, there has been a great deal of clinical interest in FLT3 as a therapeutic target and a number of small molecule inhibitors with inhibitory activity against FLT3 have entered clinical trials (9). Although many of the patient responses seen in the early FLT3 monotherapy trials were limited in both depth and duration (10-14), there have been more recent reports of deeper, sustained remissions from newer, more potent FLT3 inhibitory compounds (15;16).

Lestaurtinib (previously CEP-701), one of the so-called 'first generation' of FLT3 inhibitors, is an orally-available indolocarbazole alkaloid compound that was identified as a potent inhibitor of FLT3 (**in both its ITD- and point-mutated configurations**) at low nanomolar *in vitro* concentrations (17) after originally being developed as a TrkA neurotrophin receptor inhibitor(18); it is also a potent inhibitor of JAK2(19;20). Lestaurtinib is orally bioavailable and was generally well-tolerated in two monotherapy trials, in relapsed / refractory AML patients and in older patients considered unsuitable for intensive therapy, where transient clinical responses, characterised by reductions in peripheral blood or bone marrow blasts or decreased transfusion requirements, were observed primarily in patients harbouring FLT3-activating mutations (13;14). Crucially in both of these monotherapy studies, clinical activity of Lestaurtinib correlated closely with evidence of achievement of sustained reduction of FLT3 phosphorylation by >85%, as determined by plasma inhibitory activity (PIA) assay (21).

Synergistic cytotoxicity to FLT3-mutated AML cells was observed in the laboratory when Lestaurtinib was administered sequentially following chemotherapeutic agents (22). On this basis, the combination of Lestaurtinib with chemotherapy (either MEC or high dose AraC) was assessed in the Cephalon 204 trial, a randomised phase III study in patients with relapsed FLT3-mutated AML (23). Although no significant improvements in second complete remission (CR) rate or OS were demonstrated with the addition of Lestaurtinib, correlation was again observed between *in vivo* FLT3 inhibition and achievement of clinical response;

however a disappointing proportion Cephalon 204 study patients failed to achieve free drug levels sufficient to achieve optimal FLT3 inhibitory activity.

The published randomised clinical trial experience of FLT3-targeted kinase inhibitors has so far been limited to the difficult-to-treat population of AML patients with relapsed or refractory disease. The potential clinical benefit of combining FLT3-targeted therapy with first-line intensive chemotherapy in patients with previously-untreated AML has not yet been formally established. We undertook the first prospective randomised assessment of the addition, or not, of oral Lestaurtinib, given sequentially following each cycle of chemotherapy, to newly-diagnosed AML patients presenting with a *FLT3*-ITD or *FLT3*-TKD mutation. This intervention was part of the UK MRC AML15 (ISRCTN17161961) and carried forward, with the data blinded, into the UK NCRI AML17 (ISRCTN55675535) trial.

Methods

Study design and participants

The UK MRC AML15 and NCRI AML 17 studies (ISRCTN 17161961 and 55675535) were large, prospective phase 3 multi-centre trials for patients with newly-diagnosed AML or high risk myelodysplastic syndrome (MDS) (>10% marrow blasts) which ran consecutively between May 2002 and December 2014 at >130 centres in the United Kingdom, Denmark and New Zealand and addressed several randomised questions (**Supplemental Table 1**). During 2007 to October 2012 patients with a *FLT3* mutation could be randomised to Lestaurtinib or not. Patients were generally aged <60yrs, although older patients could be entered if considered suitable for intensive chemotherapy. Patients with acute promyelocytic leukemia or blast transformation of chronic myeloid leukemia were not eligible for randomisation.

Both trials were sponsored by Cardiff University and approved by Wales REC3 on behalf of all UK investigators, by the Danish Medicines Agency for sites in Denmark, and by MEDSAFE for sites in New Zealand. The trials were conducted in accordance with the Declaration of Helsinki, written consent being required for each randomisation.

The trial designs of AML15 and AML17 involved a number of randomised interventions (**Figure 1**). Induction chemotherapy (courses 1-2) was with ADE, DA or FLAG-Ida with or without gemtuzumab ozogamicin (GO) in course 1; consolidation (courses 3-4) comprised high dose cytarabine (1.5g/m² or 3g/m²) or MACE/MidAC. Allogeneic stem cell transplantation was permitted for patients with intermediate- or poor-risk disease with a recommendation of myeloablative conditioning for patients aged <35 years and reduced intensity conditioning for patients >45 years, with investigator/patient choice in the intermediate age group in AML15, but was recommended only for poor risk patients in AML17. In neither trial was *FLT3* status an indication for transplant.

Patients entered the allocated first induction chemotherapy course during which investigators were informed of the *FLT3* mutation status which was centrally-ascertained for all patients in one of two reference labs. Patients confirmed to harbour a *FLT3* mutation (*FLT3* ITD or TKD mutation quantified at $\geq 5\%$ of total *FLT3* alleles) **were able to enter the Lestaurtinib randomisation and to start the allocated treatment 48 hours after completion of course 1 of induction treatment.**

Lestaurtinib randomisation and treatment schedule

In AML15, eligible patients were randomised in a 1:1 ratio to receive Lestaurtinib, or not, following each of four courses of chemotherapy. In AML17, this randomisation was placebo controlled, with an allocation ratio of 2:1 Lestaurtinib to placebo. In both studies, treatment allocation was by web-based computer minimisation hosted by Cardiff University (Cardiff, UK). Minimisation parameters were age (0-15, 16-29, 30-39, 40-49, 50-59, or 60 years and older), WHO performance status (0-4), induction treatment and *de-novo* versus secondary disease versus high risk MDS.

Lestaurtinib (Cephalon Inc, Frazer, PA) was commenced 2 days after completion of each course of chemotherapy and administered in cycles of up to 28 days for a maximum of 4 cycles, being stopped at least 2 days before commencing the next course of chemotherapy (**Figure 1**). The initial dose was 80mg orally twice daily (bd) (12 hours between doses); if well-tolerated an increase to a maximum dose of 100mg bd was permitted from cycle 2 onwards. In case of additional toxicity, which was anticipated with the co-administration of azole anti-fungal drugs (which have CYP3A4 inhibitory activity), provision was made for a reduced dose of 40-60mg bd. There was no maintenance therapy with Lestaurtinib. Patients receiving allogeneic stem cell transplant continued Lestaurtinib until 28 days after their last pre-transplant course of chemotherapy but did not receive further Lestaurtinib following transplant.

Correlative Studies

Whole-blood samples were requested to be sent to the central UK lab on day 14 (+/- 2 days) of each cycle of Lestaurtinib. The samples were to be taken 12 hours after the patient's most recent dose, to enable assessment of trough *FLT3* plasma inhibitory activity (PIA), trough plasma concentration of Lestaurtinib and *FLT3* ligand (FL) levels. Samples were separated by centrifugation and plasma stored frozen at -80°C before batch shipment.

The PIA assay was performed at Johns Hopkins University, Baltimore, MD as previously described (21). Briefly, frozen plasma samples were thawed and clarified by centrifugation at $16,000g$ for 2 minutes. For each time point, 2×10^6 TF/ITD cells (human AML TF-1 cell line expressing a *FLT3*-ITD construct) were incubated with 1ml patient plasma at 37°C for 1 hour. Cells were then washed twice with ice-cold phosphate-buffered saline and lysed. After immunoblotting for phosphorylated *FLT3*, densitometric analysis was performed and the

FLT3 PIA for each plasma sample was calculated by expressing the density of its corresponding band as a percentage of that obtained from baseline untreated plasma.

Day 14 trough plasma concentrations of Lestaurtinib were quantified by Cephalon Inc., West Chester, PA, using a validated high-performance liquid chromatography method as previously described (23). FL concentrations in plasma samples were determined using an ELISA kit obtained from R&D Systems (Minneapolis, US).

Statistical Analysis

All study endpoints were defined according to the Revised International Working Group Criteria (24). The primary outcome measure for the AML15 trial was OS which was amended to Relapse Free Survival (RFS) when the randomisation rolled over into AML17. Secondary endpoints were achievement of CR, CR with incomplete peripheral blood count recovery (CRi), OS from Lestaurtinib randomisation, relapse and death in remission (for patients achieving either CR or CRi), together with haematological recovery times, toxicity (scored using the National Cancer Institute Common Toxicity Criteria Version 3.0 (25)) and resource usage. Remission status was determined locally in participating centres.

All analyses are by intention-to-treat. Categorical endpoints (e.g. CR rates) were compared using Mantel-Haenszel tests to give Peto odds ratios and confidence intervals.

Continuous/scale variables were analysed by non-parametric (Wilcoxon rank sum) tests. Time-to-event outcomes were analysed using the log-rank test, with Kaplan-Meier survival curves. Odds/hazard ratios (OR/HR) <1 indicate benefit for Lestaurtinib. All survival percentages are at 5 years unless otherwise stated. Because of the change of design between AML15 and AML17, the two trials have been meta-analysed using standard methodology (26) and meta-analytic survival curves plotted.

In addition to overall analyses, exploratory analyses were performed stratified by the randomisation stratification parameters and other important variables, with suitable tests for interaction. Because of the well-known dangers of subgroup analysis, these were interpreted cautiously.

Analyses of correlative laboratory studies were carried out using logrank tests and Cox proportional hazards regression for multivariable analyses. Repeated measures analyses were carried out using multilevel models repeated measure analyses.

Follow-up is complete until 1st March 2015, with a median follow-up for survival of 50.5 months (range 1.3-97 months) and 288 events.

Results

Patients

Between January 2007 and January 2009, 967 adult non-APL patients entered the AML15 trial and were eligible for *FLT3* testing of whom 215 had a *FLT3* mutation (ITD alone n=156, TKD point mutation alone n=45, both n=3; mutation type undetermined n=7). Between April 2009 and October 2012, 1708 patients entered AML17, of whom 406 were identified as having a *FLT3* mutation (ITD alone n=297, TKD alone n=94, both n=12; mutation type undetermined n=3). In total, 500 *FLT3* mutated patients (AML15 n=175, AML17 n=325; 370 (74%) who had ITD alone, 115 (23%) with TKD alone and 11 (2%) who had both; **median ITD mutant percentage 30.9%; range 3-98.4; 57 patients with allelic ratio ≥50%**) entered the randomisation; 4 patients the mutation type was not determined; for 2 patient the ITD allelic ratio was found to be <5% but these are included in the above. . The characteristics of patients **which were balanced between the arms**, are shown in **Table 1**. The median age of *FLT3*-randomised patients was 49 years (range 5-68); 5 patients aged below 16 years were included. 94% of patients had *de novo* AML, 5% secondary AML and 1% high risk MDS. The majority of patients (89%) had cytogenetically intermediate risk disease with 6% favourable and 5% adverse risk. Median presenting WBC was $28 \times 10^9/l$ (range 0.2-363). 270 patients (54%) had concomitant mutated *NPM1c*. All disease characteristics were balanced between Lestaurtinib and control arms as were the other treatment interventions.

The disposition of the patients is shown in Figure 2.

Overall Response

Patients received a median of 3 cycles of Lestaurtinib (range 0-4). With median follow-up of 50.5 months (range 1.3-97.8) 5-year OS is 45% for all patients randomised: outcomes were stratified by treatment arm and trial and are summarised in **Table 2**. There was no overall difference in remission rate (combined CR/CRi at any time) between treatment arms (Lestaurtinib 92%, control 94%, OR 1.37 (0.68-2.78), $p=0.4$).

Relapse Free and Overall Survival

No significant differences were seen in either 5-year RFS (Lestaurtinib 40% vs Control 36%, HR 0.88 (0.69-1.12), $p=0.3$) or OS (Lestaurtinib 46% vs Control 45%, HR 0.90 (0.70-1.15), $p=0.3$) (**Figure 3**). Analyses stratified by trial (AML15 vs 17) showed no heterogeneity of effect of Lestaurtinib on any endpoint (**Figure 3, Table 2**).

Transplant

A total of 226 (45%) patients received a stem cell transplant (45% in each arm) at some stage, with 198 of these being allografts (control 42%, Lestaurtinib 38%), and 122 allografts being delivered in first remission (25% vs 24%) (**Table 1**). Censoring survival at the time of stem cell transplant did not materially change the results (HR 0.92 [0.67-1.25] $p=0.6$) (**Figure 3a**).

Safety and toxicity

Overall, across AML15 and 17, only marginal differences in toxicity were seen between the Lestaurtinib and control arms and there was no significant difference in early (30-day or 60-day) mortality (**Supplemental Figure 1**). There were moderate increases in nausea and diarrhoea with Lestaurtinib in the first two courses of treatment and a slightly higher grade of bilirubin in course 1. More antibiotics were required by Lestaurtinib-treated patients in courses 1 and 2 and there were also slightly higher supportive care needs during course 2, associated with a 2-day increase in median time to platelet recovery ($p=0.01$) (**Supplemental Table 2, Supplemental Figure 1**). In the AML17 study, where comparisons could be made, no significant differences were noted between compliance with Lestaurtinib (91%) and placebo (95%) therapy during course 1.

Exploratory Sub-group Analysis

Exploratory sub-group analyses were performed by age, sex, diagnosis (de novo / secondary / MDS), cytogenetics, risk group, performance status, type of *FLT3* mutation, *FLT3* mutant allelic burden and *NPM1* mutation status. No significant interactions were found (**Supplemental Figure 2**), so we explored potential interaction with treatments in the trial including the use of concomitant anti-fungal prophylaxis (**Figure 4a**) and with the individual azole drugs (fluconazole, itraconazole, posaconazole or voriconazole) (**Figure 4b**). We noted that although there was no significant interaction with azole therapy, there appeared to be a significantly superior survival in recipients of Lestaurtinib who were on azole prophylaxis (HR 0.57 (0.36-0.92), $p=0.02$; this appears to be due to better survival following relapse for which there is no obvious explanation; there was no evidence of azole-related reduction in relapse itself or benefit on CR rate. No other significant treatment interactions were seen, and in particular, the type of azole prophylaxis did not seem to affect the benefit, although for patients in the AML17 trial who received both gemtuzumab ozogamicin (GO) and an azole, the addition of Lestaurtinib provided additional benefit (**Figure 4c**), **which resulted from a combination of a non-significant reduction in relapse (HR 0.62 (0.35-1.12) $p=0.11$) and significantly better survival post relapse (HR 0.49 (0.25-0.97) $p=0.04$).**

Correlative pharmacodynamic / pharmacokinetic studies

To estimate the degree of FLT3 inhibition achieved in vivo, trough FLT3 plasma inhibitory activity (PIA) was measured at day 14 of each cycle of Lestaurtinib. **The PIA assay utilises FLT3-dependent cell line TF1-ITD as a 'surrogate tissue', allowing FLT3-inhibitory activity to be assessed after clearance of leukemia cells from the blood/marrow.** It has previously been hypothesised, based on data from pre-clinical and early phase monotherapy studies of Lestaurtinib, that sustained inhibition of FLT3 phosphorylation by more than 85% (i.e. to less than 15% of its baseline activity) is required in order to achieve a cytotoxic, and clinically-relevant, response to the drug.^{11,12}

Plasma inhibitory assays at trough were carried out on 83 patients, at a total of 161 timepoints; a FLT3 PIA of >85% was seen at 118/161 (73%) of all evaluated time points. 82%

of the patients (68/83) achieved at least one FLT3 PIA measurement in excess of 85%, with 64% (53/83) showing >85% inhibition at all assayed timepoints. Although no relationship was seen between FLT3 PIA and the successful induction of remission, rates of relapse were significantly lower in patients who achieved sustained FLT3 inhibition (FLT3 PIA >85% at *all* evaluated time points) (43% in inhibited vs 68% in non-inhibited patients, HR 0.44 (0.23-0.86) $p=0.02$, **Figure 5A**) leading to a significantly better OS (60% vs 33%, HR 0.50 (0.26-0.97) $p=0.04$, **Figure 5B**). **Although** FLT3 inhibition appeared to be greater in patients with *NPM1c* mutations (81% vs 39% inhibited, $p=0.003$) **the relationship between PIA and clinical outcome remained significant after adjusting for NPM1 mutation status**. Although there was some evidence of a beneficial effect of co-administration of azoles on survival, this was attributable to better post-relapse survival rather than relapse itself, and was not explained by a difference in the PIA levels in azole treated patients **(44/64 inhibited with concomitant azole; 13/18 inhibited without $p=0.8$)**. Day 14 trough plasma Lestaurtinib levels were measured in 155 patients after course 1. The median plasma level of Lestaurtinib in course 1 was 3996ng/ml. Patients who were inhibited according to the FLT3 PIA tended to have higher levels of Lestaurtinib during course 1 (median 5663 ng/ml vs 3092 ng/ml $p=0.002$).

Among the 83 patients where PIA measurements were carried out, mean day 14 FLT3 ligand (FL) concentrations rose through successive courses of Lestaurtinib treatment from 496pg/ml during course 1 to 1467pg/ml, 2565pg/ml and 2720pg/ml during courses 2, 3 and 4 ($p<.0001$ by repeated measures analysis). Despite these rising FL levels, no apparent fall off in the proportion of patients successfully achieving optimal levels of FLT3 inhibition was observed; a day 14 FLT3 PIA level in excess of 85% was achieved in 73% of assayed patients during course 1 (47/64), 76% during course 2 (38/50), 80% during course 3 (24/30) and 53% during course 4 (9/17). Additionally, no significant correlation was seen between PIA values and FL concentrations in a repeated measures analysis across all time points ($p=0.14$).

Discussion

In this prospective randomised assessment, we sought to establish whether the FLT3-targeted inhibitor Lestaurtinib, added sequentially to standard front-line chemotherapy, would improve the clinical outcome for newly-diagnosed younger AML patients with *FLT3*-mutated disease. By intention-to-treat analysis, no statistically significant evidence of benefit was seen: Lestaurtinib failed to reach its primary endpoints of improving OS or RFS, there was no improvement in remission rate or evidence of sub-group benefit restricted according to type of *FLT3* mutation, *FLT3*-ITD mutant allelic burden or accompanying *NPM1* mutation. Unplanned sub-group analysis did suggest potential benefit with Lestaurtinib when combined with azoles and GO in induction.

In the wider context of FLT3-directed therapy, the most encouraging aspect of our results was the demonstration that achievement of sustained levels of in vivo FLT3 inhibition,

quantified using the FLT3 PIA assay, correlated with significantly improved patient outcome in terms of reduced relapse rate and improved OS; these findings augment those of the Cephalon 204 trial in which 39% of relapsed FLT3-AML patients with >85% FLT3 inhibition during their first course of Lestaurtinib plus chemotherapy achieved a second CR compared to only 9% of sub-optimally-inhibited patients (23). Such data appear to re-emphasise the validity of FLT3 as a therapeutic target in previously-untreated and relapsed AML, but underline that Lestaurtinib is unlikely to be the best drug for future clinical exploitation. Although the number of patients with a full set of assays is limited, 27% of assayed AML15/17 cases (compared to 42% in Cephalon 204) failed to maintain adequate sustained FLT3 inhibition and, as in that trial, large inter-patient variations were observed in steady state plasma Lestaurtinib concentrations. We were unable to explain the observed azole benefit in terms of any impact of azoles on PIA levels. Lestaurtinib is known to be highly plasma protein-bound; it has previously been suggested that levels of free, biologically-active drug fall as levels of plasma proteins rise during chemotherapy (23). This combination of pharmacokinetic limitations make it unlikely to be possible to dose Lestaurtinib in a schedule that delivers sustained FLT3 inhibition while maintaining tolerability.

Progressively rising levels of FLT3 ligand (FL), measured as patients with relapsed AML receive chemotherapy, but seemingly independent of FLT3 inhibitor exposure, have been hypothesised as one mechanism of resistance to FLT3 inhibition; adding FL to *in vitro* assays significantly blunted the efficacy of a panel of FLT3 inhibitors against cell lines and primary AML blasts (27). In AML15/17, we demonstrated that rising FL levels, again evident as patients progressed through chemotherapy, failed to impede target inhibition; no fall off was seen in the proportion of patients achieving adequate FLT3 PIA through successive treatment cycles, no inverse correlation was observed between FL concentration and FLT3 PIA **and there was no association between FL level and clinical outcome** These data provide encouragement that rising FL levels may not prove an insurmountable obstacle to successful combination of FLT3 inhibition with chemotherapy.

The clinical benefit seen in the azole recipients may reflect the general benefit of azole therapy in AML treatment although we saw no difference in 30- and 60-day mortality with azole treatment. The additional clinical benefit observed with the concomitant use of GO in induction is especially interesting in the context of our recently-published extended follow-up data from AML17 which identified *FLT3*-ITD patients as the only sub-group to benefit from increasing course 1 daunorubicin dose from 60 to 90mg/m²; late benefits were seen in terms of relapse reduction and improved RFS and OS (28). This potential benefit of intensified induction therapy in *FLT3*-ITD cases was also highlighted in extended follow-up data from the ECOG E1900 study (29) .

Over the period of recruitment of AML15/17, another large, international study, RATIFY, has prospectively assessed the addition of 'first generation' FLT3-targeted TKI therapy to standard chemotherapy in a broadly similar population of younger adults with newly-

diagnosed FLT3-mutated AML. Midostaurin (PKC412) is an indolocarbazole compound that has considerable structural homology with Lestaurtinib and an inhibitory profile that includes FLT3, c-KIT, PDGFR-B, VEGFR-2 and protein kinase C. In contrast to AML15/17, results of the RATIFY study, published to date in abstract form, point to improvement in both OS and EFS in Midostaurin-treated patients (51% vs 43% 5-year OS, $p=0.007$) (30). In the absence of any correlative *in vivo* data from RATIFY to suggest differences in the degrees of FLT3 inhibition achieved by Midostaurin and Lestaurtinib, the reasons for the apparent discrepancies in clinical outcome between the studies remain a matter of speculation; the incorporation of maintenance FLT3 inhibition upon completion of chemotherapy in RATIFY (not permitted in AML15/17) could be relevant as could the greater proportion of patients receiving allogeneic SCT in RATIFY (57% versus 43% in AML15/17), or the differences in 'non-FLT3' kinase inhibitory profiles of the compounds. Certainly the incorporation of formal prospective randomised assessment of the value of maintenance FLT3-directed therapy, including post-transplant, will be pertinent to the design of future 'FLT3 inhibitor plus chemotherapy' studies.

The longer term future of this 'first generation' of FLT3 inhibitors, relatively non-selective compounds that were originally developed to target other kinases, is uncertain. Over the lifetime of the AML15/17 study a second generation of **more selective** FLT3 inhibitors with more restricted 'off target' activity and the apparent capability of achieving sustained profound FLT3 inhibition in a tolerable fashion, have achieved deeper, longer-lasting remissions in the setting of monotherapy of relapsed / refractory FLT3-AML (15;16), and are moving into combination with chemotherapy. Differences are well documented between the biology of FLT3/ITD AML at initial diagnosis and at relapse, however. *In vitro* data support that, whereas relapsed FLT3-driven disease may be particularly vulnerable to highly-selective FLT3 inhibition due to the impact of higher *FLT3* mutant allelic burden and greater 'addiction' to FLT3 signalling, contrastingly, at the time of initial AML diagnosis, there is far less 'FLT3-dependency' and selective inhibition of FLT3 alone is usually insufficient to induce *in vitro* cytotoxicity (31). Continuing exploration of the role of multi-kinase inhibition may still, therefore, be biologically justified in the setting of newly-diagnosed *FLT3*-mutated AML. The mixed clinical experiences with Lestaurtinib in AML15/17 have, however, re-emphasised the necessity of optimising pharmacokinetics when combining kinase inhibition with chemotherapy and underlined the importance of continuing to correlate clinical response with laboratory evidence of target inhibition in future studies.

Acknowledgements

The AML15 and AML17 trials were supported, respectively, by research funding from the UK Medical Research Council and Cancer Research UK. The authors thank the staff of the Cardiff University Haematology Trials Unit for supervision of the trials. We are grateful to Cephalon Inc (Dr Peter Brown and Dr Debra Kennedy) and subsequently Teva for provision of Lestaurtinib. Correlative

pharmacodynamic laboratory studies at Johns Hopkins University (FLT3 PIA and FL assays) were supported by the US National Cancer Institute (MD Anderson Leukemia SPORE P50 CA100632). Pharmacokinetic analysis was funded and hosted by Cephalon Inc .

Authorship

Contribution: A.K.B. was the lead investigator, designed the study and wrote the manuscript; S.K. coordinated the study, oversaw correlative studies and wrote the manuscript; N.R. designed and coordinated the study; A.G. and R.E.G. designed and oversaw molecular analysis; R.K.H. provided statistical input to the study design, analysed data and wrote the manuscript; J.C., G.J. and L.K. provided patients to the study; M.L. designed, coordinated and performed correlative studies; M.R.G. and H.K. performed and analysed correlative studies; I.T. coordinated the conduct of the study and data collection. All authors reviewed the manuscript prior to submission.

Conflict-of-interest disclosure: A.K.B., S.K and M.L. served on the Clinical Advisory Board of Cephalon Inc. A.K.B. is currently an employee of CTI Life Sciences. The remaining authors declare no competing financial interests.

List of clinicians who entered patients into the trials:

Aalborg University Hospital: Dr Mette Skov Holm, Dr Maria Kallenbach; **Aarhus University Hospital:** Dr J M Norgaard; **Aberdeen Royal Infirmary:** Dr J. Tighe; **Addenbrooke's Hospital:** Dr J Craig, Dr C Crawley, Dr Jane Keidan, Dr George Vassilou; **Arrowe Park Hospital:** Dr Ranjit Dasgupta; **Auckland City Hospital:** Dr Leanne Berkhan, Dr Peter Bowett, Dr Richard Doocey, Dr Shannon Emmett, Dr Timothy Hawkins, Dr Nigel Patton; **Barnet General Hospital:** Dr Andres Virchis; **Barts and the London NHS Trust:** Dr J Cavenagh, Dr John Gribben, Dr Matthew Smith, Dr David Taussig; **Basingstoke and North Hampshire Foundation NHS Trust:** Dr Sylwia Simpson; **Beatson West of Scotland Cancer Centre:** Dr Mark Drummond, Dr Pam McKay, Dr Anne Parker, Dr Richard Soutar; **Belfast City Hospital:** Dr Robert Cuthbert, Dr Damian Finnegan, Dr F Jones, Dr Mary Frances McMullin; **Birmingham Heartlands Hospital:** Dr D W Milligan, Dr Shankara Paneesha, Dr Neil Smith; **Blackpool Victoria Hospital NHS Foundation Trust:** Dr P A Cahalin; **Bradford Royal Infirmary:** Dr L J Newton; **Bristol Haematology and Oncology Centre:** Dr R Evely, Dr G R Standen; **Christchurch Hospital:** Dr Andrew Butler, Dr Peter Ganly, Dr Steve Gibbons, Dr Ruth Spearing; **Christie Hospital NHS Trust:** Dr M Dennis; **City Hospitals Sunderland:** Dr Yogesh Upadhye; **Countess of Chester Hospital:** Dr Edwin Lee, Dr Salah Tuegar; **Crosshouse Hospital:** Dr P.D. Micallef-Eynaud; **Darent Valley Hospital:** Dr R Ezekwesili, Dr Tariq Shafi; **Derby Hospitals NHS Foundation Trust:** Dr Juanah Addada, Dr A Mckernan, Dr Christopher Millar; **Derriford Hospital:** Dr Adrian Copplestone, Dr Mike Hamon, Dr Hannah Hunter, Dr Simon Rule; **Doncaster Royal Infirmary:** Dr S Kaul; **Dorset County Hospital NHS Foundation Trust:** Dr A.H. Moosa; **Dumfries & Galloway Royal Infirmary:** Dr R Thomas; **Eastbourne District General Hospital:** Dr R J Grace; **Falkirk and District Royal Infirmary:** Dr Christopher Brammer, Dr Marie Hughes, Dr Roderick Neilson; **Gartnavel General Hospital:** Dr E.J. Fitzsimons; **Gloucestershire Royal Hospital:** Dr Eve Blundell, Dr Sally Chown, Dr Rebecca Frewin, Dr Adam Rye; **Great Western Hospital:** Dr N E Blessing, Dr Atherton Gray; **Guys and St Thomas' Foundation Trust:** Dr R Carr, Dr Kavita Raj; **Hammersmith Hospital:** Dr David Marin, Dr Jiri Pavlu; **Heatherwood and Wexham Park NHS Foundation Trust:** Dr N. Bienz, Dr P. H. Mackie; **Hemel Hempstead General Hospital:** Dr J Harrison; **Hereford County Hospital:** Dr Sara Willoughby; **Herlev University Hospital:** Dr Inge Hoegh Dufva, Dr Morten Krogh Jensen; **Hillingdon Hospital:** Dr R Kaczmarek, Dr Taku Sugai; **Hull Royal Infirmary:** Dr Sahra Ali; **Ipswich Hospital NHS Trust:** Dr Debo Ademokun, Dr Isobel Chalmers, Dr Andrew Hodson; **James Cook University Hospital:** Dr Ray Dang, Dr Angela Wood; **James Paget University Hospital:** Dr Cesar Gomez; **John Radcliffe Hospital:** Dr Paresh Vyas; **Kent & Canterbury Hospital:** Dr C F E Pocock, Dr V Ratnayake, Dr K Saied, Dr F Zwaan; **Kettering General Hospital:** Dr Mark Kwan, Dr I Wilson-Morkeh; **Leicester Royal Infirmary:** Dr Ann Hunter, Dr Murray Martin; **Lincoln County Hospital:** Dr Kandeepan Saravanamuttu; **Maidstone District General Hospital:** Dr D Gillett, Dr Saad Rassam; **Maidstone Hospital:** Dr Richard Gale; **Manchester Royal Infirmary:** Dr G S Lucas, Dr Eleni Tholouli, Dr John Yin; **Medway Maritime Hospital:** Dr Maadh Aldouri, Dr V E Andrews; **Milton Keynes Hospital NHS Foundation**

Trust: Dr Moez Dungarwalla; **Monklands Hospital:** Dr John Murphy, Dr Pamela Paterson; **New Cross Hospital:** Dr Supratik Basu, Dr Sunil Hada, Dr A Jacob; **Ninewells Hospital:** Dr Keith Gelly, Professor M J Pippard, Dr S Tauro; **Norfolk and Norwich University Hospital NHS Foundation Trust:** Dr Matthew Lawes; **North Middlesex University Hospital:** Dr Neil Rabin; **Northampton General Hospital:** Dr Suchitra Krishnamurthy; **Northwick Park Hospital:** Dr Nicki Panoskaltzis, Dr C D L Reid; **Nottingham University Hospitals NHS Trust:** Dr J L Byrne, Dr Emma Dasgupta, Dr Nigel Russell; **Odense University Hospital:** Dr Lone Friis; **Palmerston North Hospital:** Dr Bart Baker; **Pinderfields General Hospital:** Dr Paul Moreton, Dr D Wright; **Poole General Hospital:** Dr A J Bell, Dr Fergus Jack; **Princess Royal University Hospital:** Dr C De Lord, Dr Bipin Vadhir; **Queen Alexandra Hospital:** Dr Robert Corser, Dr T Cranfield, Dr Helen Dignum, Dr C M James; **Queen Elizabeth Hospital Birmingham:** Dr Charles Craddock, Dr P. Mahendra, Dr J.A. Murray; **Queens Hospital:** Dr Claire Hemmaway; **Rigshospitalet:** Dr Peter Kampmann, Dr Lars Kjeldsen, Dr Ove Juul Nielsen, Dr Carsten Niemann; **Rotherham District General Hospital:** Dr H F Barker; **Royal Berkshire Hospital:** Dr H Grech, Dr Henri Groch, Dr Stuart Mucklow, Dr Rebecca Sampson; **Royal Bournemouth Hospital:** Dr Joseph Chacko, Dr S Killick; **Royal Cornwall Hospital:** Dr Julie Blundell, Dr Richard Noble, Dr Bryson Pottinger; **Royal Devon and Exeter Hospital:** Dr Malcolm Hamilton, Dr R Lee, Dr Claudius Rudin, Dr Anthony Todd; **Royal Free Hospital:** Dr P Kottaridis; **Royal Hallamshire Hospital:** Dr C Dalley; **Royal Hospital for Sick Children (Yorkhill):** Dr Brenda Gibson; **Royal Marsden Hospital:** Dr M Ethell; **Royal Oldham:** Dr Allameddine Allameddine; **Royal Surrey County Hospital:** Dr Johannes DeVos, Dr Elisabeth Grey-Davies, Dr Louise Hendry, Dr G Robbins; **Royal United Hospital Bath:** Dr Josephine Crowe, Dr Chris Knechtli; **Russells Hall Hospital:** Dr Savio Fernandes, Dr J Neilson; **Salford Royal Hospital:** Dr John Houghton, Dr Simon Jowitt, Dr Sonya Zaman; **Salisbury Hospital NHS Foundation:** Dr J O Cullis, Dr Effie Grand; **Sandwell Hospital:** Dr Y Hasan, Dr Farooq Wandoo; **Sheffield Children's NHS Foundation Trust:** Dr Ajay Vora; **Singleton Hospital:** Dr S Al-Ismail, Dr Saad Ismail; **South Devon Healthcare NHS Foundation Trust:** Dr Patrick Roberts; **Southampton General Hospital:** Dr Mary Morgan, Dr K Orchard, Dr Deborah Richardson; **Southern General Hospital:** Dr Anne Morrison; **St George's Hospital:** Dr F Willis; **St James's University Hospital:** Dr David Bowen, Dr Geoffrey Shenton; **St Peter's Hospital:** Dr A Miller; **St Richard's Hospital:** Dr Phillip Bevan, Dr Sarah Janes, Dr P Stross; **Stafford Hospital:** Dr Paul Revell; **Stoke Mandeville Hospital:** Dr A M O'Hea, Dr Anne-Marie O'Hea, Dr Jonathan Pattinson; **Taunton and Somerset Foundation Trust:** Dr Simon Bolam; **The Newcastle upon Tyne NHS Foundation Trust:** Dr Simon Bailey, Dr Graham Jackson, Dr Gail Jones, Dr Anne Lennard, Professor Steve Proctor; **The Royal Liverpool University Hospital:** Dr R.E. Clark, Dr Rahuman Salim; **University College London Hospitals:** Dr S D'Sa, Dr Victoria Grandage, Dr A Khwaja, Dr A Nathwani, Dr Nishal Patel, Dr Kwee Yong; **University Hospital Aintree:** Dr Walid Sadik; **University Hospital Coventry (Walsgrave):** Dr Syed Bokhari, Dr Anton Borg, Dr Jagdeesh Gandla, Dr Beth Harrison, Dr N Jackson, Dr M Narayanan, Dr Peter Rose; **University Hospital of North Staffordshire NHS Trust:** Dr Deepak Chandra, Dr R C Chasty, Dr Srinivas Pillai, Dr Andrew Stewart; **University Hospital of North Tees and**

Hartlepool: Dr Zor Maung, Dr Philip Mounter; **University Hospital of Wales:** Dr Jonathan Kell, Dr Steve Knapper, Dr C Rowntree; **Victoria Hospital NHS Fife:** Dr Kerri Davidson, Dr Lorna McLintock, Dr S Rogers, Dr Peter Williamson; **Waikato Hospital:** Dr Humphrey Pullon; **Warwick Hospital:** Dr Peter E Rose; **Wellington Hospital:** Dr John Carter, Dr Alwyn D'Souza; **West Middlesex University Hospital:** Dr R G Hughes; **Western General Hospital:** Dr P R E Johnson, Dr P H Roddie; **Whiston Hospital:** Dr Toby Nicholson, Dr G Satchi; **Wishaw General Hospital:** Dr Gila Helenglass; **Worcestershire Royal Hospital:** Dr Juliet Mills, Dr N Pemberton, Dr A H Sawers, Dr S Shafeek; **Worthing Hospital:** Dr Santosh Narat; **Wycombe General Hospital:** Dr S Kelly; **York Hospital:** Dr L R Bond, Dr M.R. Howard; **Ysbyty Glan Clwyd:** Dr M J Goodrick, Dr Earnest Heartin, Dr C Hoyle; **Ysbyty Gwynedd:** Dr James Seale.

Reference List

- (1) Nakao M, Yokota S, Iwai T, Kaneko H, Horiike S, Kashima K et al. Internal tandem duplication of the *flt3* gene found in acute myeloid leukemia. *Leukemia* 1996 December;10(12):1911-8.
- (2) Yamamoto Y, Kiyoi H, Nakano Y, Suzuki R, Koderu Y, Miyawaki S et al. Activating mutation of D835 within the activation loop of FLT3 in human hematologic malignancies. *Blood* 2001 April 15;97(8):2434-9.
- (3) Levis M, Small D. FLT3: IT Does matter in leukemia. *Leukemia* 2003 September;17(9):1738-52.
- (4) Kottaridis PD, Gale RE, Frew ME, Harrison G, Langabeer SE, Belton AA et al. The presence of a FLT3 internal tandem duplication in patients with acute myeloid leukemia (AML) adds important prognostic information to cytogenetic risk group and response to the first cycle of chemotherapy: analysis of 854 patients from the United Kingdom Medical Research Council AML 10 and 12 trials. *Blood* 2001 September 15;98(6):1752-9.
- (5) Thiede C, Steudel C, Mohr B, Schaich M, Schakel U, Platzbecker U et al. Analysis of FLT3-activating mutations in 979 patients with acute myelogenous leukemia: association with FAB subtypes and identification of subgroups with poor prognosis. *Blood* 2002 June 15;99(12):4326-35.
- (6) Frohling S, Schlenk RF, Breitnick J, Benner A, Kreitmeier S, Tobis K et al. Prognostic significance of activating FLT3 mutations in younger adults (16 to 60 years) with acute myeloid leukemia and normal cytogenetics: a study of the AML Study Group Ulm. *Blood* 2002 December 15;100(13):4372-80.
- (7) Gale RE, Green C, Allen C, Mead AJ, Burnett AK, Hills RK et al. The impact of FLT3 internal tandem duplication mutant level, number, size, and interaction with NPM1 mutations in a large cohort of young adult patients with acute myeloid leukemia. *Blood* 2008 March 1;111(5):2776-84.
- (8) Mead AJ, Linch DC, Hills RK, Wheatley K, Burnett AK, Gale RE. FLT3 tyrosine kinase domain mutations are biologically distinct from and have a significantly more favorable prognosis than FLT3 internal tandem duplications in patients with acute myeloid leukemia. *Blood* 2007 August 15;110(4):1262-70.
- (9) Knapper S. The clinical development of FLT3 inhibitors in acute myeloid leukemia. *Expert Opin Investig Drugs* 2011 October;20(10):1377-95.
- (10) Stone RM, DeAngelo DJ, Klimek V, Galinsky I, Estey E, Nimer SD et al. Patients with acute myeloid leukemia and an activating mutation in FLT3 respond to a small-molecule FLT3 tyrosine kinase inhibitor, PKC412. *Blood* 2005 January 1;105(1):54-60.
- (11) DeAngelo DJ, Stone RM, Heaney ML, Nimer SD, Paquette RL, Klisovic RB et al. Phase 1 clinical results with tandutinib (MLN518), a novel FLT3 antagonist, in patients with acute myelogenous leukemia or high-risk myelodysplastic syndrome: safety, pharmacokinetics, and pharmacodynamics. *Blood* 2006 December 1;108(12):3674-81.

- (12) O'Farrell AM, Foran JM, Fiedler W, Serve H, Paquette RL, Cooper MA et al. An innovative phase I clinical study demonstrates inhibition of FLT3 phosphorylation by SU11248 in acute myeloid leukemia patients. *Clin Cancer Res* 2003 November 15;9(15):5465-76.
- (13) Smith BD, Levis M, Beran M, Giles F, Kantarjian H, Berg K et al. Single-agent CEP-701, a novel FLT3 inhibitor, shows biologic and clinical activity in patients with relapsed or refractory acute myeloid leukemia. *Blood* 2004 May 15;103(10):3669-76.
- (14) Knapper S, Burnett AK, Littlewood T, Kell WJ, Agrawal S, Chopra R et al. A phase 2 trial of the FLT3 inhibitor lestaurtinib (CEP701) as first-line treatment for older patients with acute myeloid leukemia not considered fit for intensive chemotherapy. *Blood* 2006 November 15;108(10):3262-70.
- (15) Altman JK, Perl AE, Cortes JE, Levis MJ, Smith CC, Litzow MR et al. Antileukemic activity and tolerability of ASP2215 80mg and greater in FLT3 mutation-positive subjects with relapsed or refractory acute myeloid leukemia: results from a phase 1/2, open-label, dose-escalation / dose-response study. *Blood* 126[23], 321a. 2015.
- (16) Cortes JE, Tallman MS, Schiller G, Trone D, Gammon G, Goldberg S et al. Results of a phase 2, randomized, open-label, study of lower doses of Quizartinib (AC220) in subjects with FLT3-ITD positive relapsed or refractory acute myeloid leukemia (AML). *Blood* 122[21], a. 2013.
- (17) Levis M, Allebach J, Tse KF, Zheng R, Baldwin BR, Smith BD et al. A FLT3-targeted tyrosine kinase inhibitor is cytotoxic to leukemia cells in vitro and in vivo. *Blood* 2002 June 1;99(11):3885-91.
- (18) Marshall JL, Kindler H, Deeken J, Bhargava P, Vogelzang NJ, Rizvi N et al. Phase I trial of orally administered CEP-701, a novel neurotrophin receptor-linked tyrosine kinase inhibitor. *Invest New Drugs* 2005 January;23(1):31-7.
- (19) Hexner EO, Serdikoff C, Jan M, Swider CR, Robinson C, Yang S et al. Lestaurtinib (CEP701) is a JAK2 inhibitor that suppresses JAK2/STAT5 signaling and the proliferation of primary erythroid cells from patients with myeloproliferative disorders. *Blood* 2008 June 15;111(12):5663-71.
- (20) Hexner EO, Mascarenhas J, Prchal J, Roboz GJ, Baer MR, Ritchie EK et al. Phase I dose escalation study of lestaurtinib in patients with myelofibrosis. *Leuk Lymphoma* 2015 September;56(9):2543-51.
- (21) Levis M, Brown P, Smith BD, Stine A, Pham R, Stone R et al. Plasma inhibitory activity (PIA): a pharmacodynamic assay reveals insights into the basis for cytotoxic response to FLT3 inhibitors. *Blood* 2006 November 15;108(10):3477-83.
- (22) Levis M, Pham R, Smith BD, Small D. In vitro studies of a FLT3 inhibitor combined with chemotherapy: sequence of administration is important to achieve synergistic cytotoxic effects. *Blood* 2004 August 15;104(4):1145-50.
- (23) Levis M, Ravandi F, Wang ES, Baer MR, Perl A, Coutre S et al. Results from a randomized trial of salvage chemotherapy followed by lestaurtinib for patients with FLT3 mutant AML in first relapse. *Blood* 2011 March 24;117(12):3294-301.
- (24) Cheson BD, Bennett JM, Kopecky KJ, Buchner T, Willman CL, Estey EH et al. Revised recommendations of the International Working Group for Diagnosis, Standardization of

Response Criteria, Treatment Outcomes, and Reporting Standards for Therapeutic Trials in Acute Myeloid Leukemia. *J Clin Oncol* 2003 December 15;21(24):4642-9.

- (25) Common Terminology Criteria for Adverse Events (version 3.0). National Institutes of Health, National Cancer Institute. 2006.
- (26) Early Breast Cancer Trials Collaborative Group. *Treatment of Breast Cancer Volume I*. 1990. Oxford, Oxford University Press.
- (27) Sato T, Yang X, Knapper S, White P, Smith BD, Galkin S et al. FLT3 ligand impedes the efficacy of FLT3 inhibitors in vitro and in vivo. *Blood* 2011 March 24;117(12):3286-93.
- (28) Burnett A, Russell N, Hills R. Higher daunorubicin exposure benefits FLT3 mutated acute myeloid leukaemia. *Blood* 2016 July 21; 128(3): 449-52.
- (29) Lusk MR, Lee JW, Fernandez HF, Abdel-Wahab O, Bennett JM, Ketterling RP et al. Benefit of high-dose daunorubicin in AML induction extends across cytogenetic and molecular groups. *Blood* 2016 March 24;127(12):1551-8.
- (30) Stone R, Mandrekar S, Sanford B, Geyer S, Bloomfield C, Dohner K et al. The multi-kinase inhibitor midostaurin prolongs survival compared with placebo in combination with daunorubicin / cytarabine induction, high-dose consolidation, and as maintenance therapy in newly diagnosed acute myeloid leukaemia patients age 18-60 with FLT3 mutations: an international prospective randomized placebo-controlled double-blind trial (CALGB 10603 / RATIFY). *Blood* 126[23], a. 2015.
- (31) Pratz KW, Sato T, Murphy KM, Stine A, Rajkhowa T, Levis M. FLT3-mutant allelic burden and clinical status are predictive of response to FLT3 inhibitors in AML. *Blood* 2010 February 18;115(7):1425-32.

Table 1: Patient Characteristics.

		AML15		AML17	
		Lestaurtinib	Control	Lestaurtinib	Placebo
Number randomised		88	87	212	113
Age group (years)	0-15	0	0	3	2
	16-29	9	10	22	10
	30-39	15	14	20	10
	40-49	24	26	57	31
	50-59	30	28	83	44
	60+	10	9	27	16
	Median (range)	48 (16-66)	46 (16-65)	50 (5-68)	50 (6-65)
Gender	Female	47	51	113	57
	Male	41	36	99	56
Type of disease	de Novo	84	84	198	104
	Secondary	3	4	10	6
	High risk MDS	0	0	4	3
Performance status**	0	54	51	127	64
	1	30	31	69	38
	2	3	2	10	6
	3	1	3	5	4
	4	0	0	0	0
WBC	0-9.9	17	25	48	29
	10-49.9	33	37	100	42
	50-99.9	19	10	31	20
	100+	18	15	20	22
	Median (range)	38.4 (0.2-363)	26.0 (1.2-308.0)	25.9 (0.8-360.0)	30.0 (0.8-285.8)
Cytogenetics	Favourable	5	6	11	5
	Intermediate	64	69	190	97
	Adverse	7	5	6	5
	Unknown	12	7	5	6
Induction treatment	AML15:				
	ADE	41	43		
	DA	43	40		
	FLAG-Ida	4	4		
	AML17: ADE*				
	ADE + GO3			38	21
	ADE + GO6			17	9
	DA + GO3			26	13
	DA + GO6			21	11
	DA60			26	14
	DA90			41	24
				44	21
	SCT:	Any	47	39	89
In 1 st CR		33	29	46	25
Allograft		41	37	73	47
Allo in CR1		32	27	40	23
FLT3 Mutation status	ITD alone	65	65	155	85
	TKD alone	22	18	52	23
	ITD+TKD	1	2	4	4
	Not assessable	0	2	1	1
	FLT3 ITD mutant percentage	<u>18</u>	<u>22</u>	<u>55</u>	<u>31</u>
	<u>38</u>	<u>22</u>	<u>77</u>	<u>47</u>	
	<u>5</u>	<u>14</u>	<u>27</u>	<u>11</u>	
	<u>5</u>	<u>9</u>	<u>0</u>	<u>0</u>	
	<u>32.5</u>	<u>36.5</u>	<u>29.5</u>	<u>31</u>	
	<u>5.8-92.5</u>	<u>3-98.4</u>	<u>5-98</u>	<u>3.5-96</u>	
NPM1c status	WT	42	34	83	52
	Mutant	43	45	124	58
	Not known	3	8	5	3

*** includes people who were not eligible for GO in AML17 and two patients mistakenly originally believed to be APL; ** 2 children did not complete the WHO performance status**

Table 2: Outcomes post Lestaurtinib Randomisation

	AML15				AML17				Overall HR/OR, 95% CI; p-value	p-value for heterogeneity by trial
	Lestaurtinib	Control	HR/OR, 95% CI	p-value	Lestaurtinib	Placebo	HR/OR, 95%CI	p-value		
ORR (CR+CRi)	91%	92%	1.14 (0.40-3.28)	0.8	93%	96%	1.58 (0.61-4.08)	0.3	1.37 (0.67-2.77) p=0.4	0.7
30d mortality	3%	2%	1.50 (0.26-8.63)	0.7	1%	0%	4.64 (0.43-49.9)	0.2	2.23 (0.54-9.14) p=0.3	0.5
60d mortality	5%	3%	1.34 (0.30-5.88)	0.7	3%	0%	4.67 (0.87-25.0)	0.07	2.31 (0.76-7.02) p=0.1	0.3
5yr OS	43%	41%	0.93 (0.63-1.38)	0.7	50%	45%	0.88 (0.64-1.21)	0.4	0.90 (0.70-1.15) p=0.4	0.8
5yr OS censored at SCT	51%	41%	0.80 (0.48-1.33)	0.4	53%	47%	0.99 (0.67-1.47)	1.0	0.92 (0.67-1.25) p=0.6	0.5
5 yr CIR	50%	50%	0.98 (0.63-1.15)	0.9	52%	62%	0.79 (0.57-1.09)	0.15	0.85 (0.66-1.10); p=0.2	0.4
5 yr CIDCR	10%	14%	0.70 (0.28-1.71)	0.4	9%	5%	1.78 (0.69-4.57)	0.2	1.08 (0.58-2.03) p=0.8	0.18
5 year RFS	40%	36%	0.92 (0.62-1.36)	0.7	39%	34%	0.85 (0.64-1.16)	0.3	0.88 (0.69-1.12) p=0.3	0.8

CR – complete remission; CRi – complete remission with incomplete count recovery; OS – overall survival; SCT – stem cell transplant; CIR – cumulative incidence of relapse; CIDCR – cumulative incidence of death in remission; RFS – relapse free survival.

Figure 1: Trial designs and treatment plan. A) AML15 (2007-9); B) AML17 (2009-11); C) AML17 (2011-14); D) Lestaurtinib treatment schedule

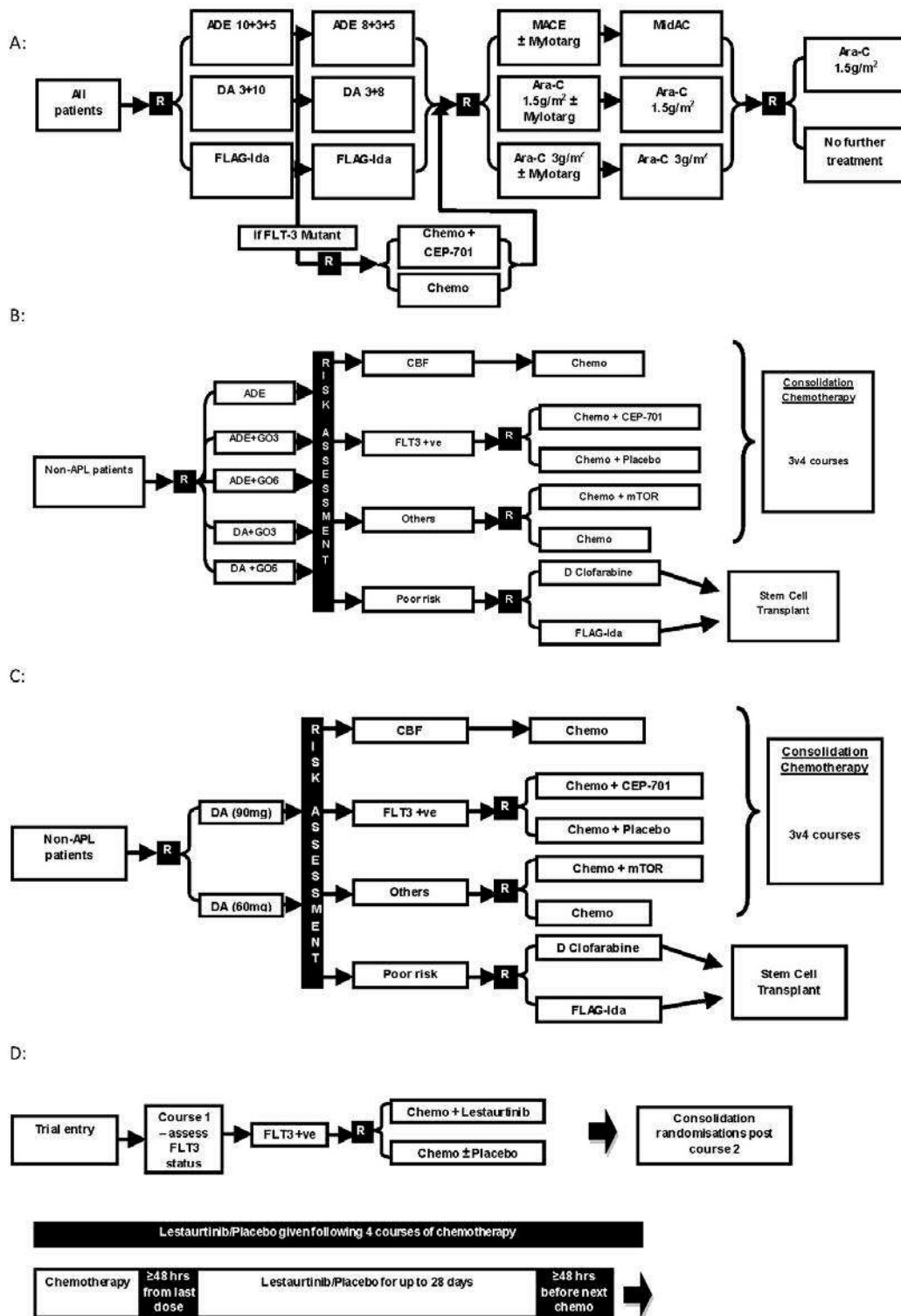

Figure 2: CONSORT Diagram

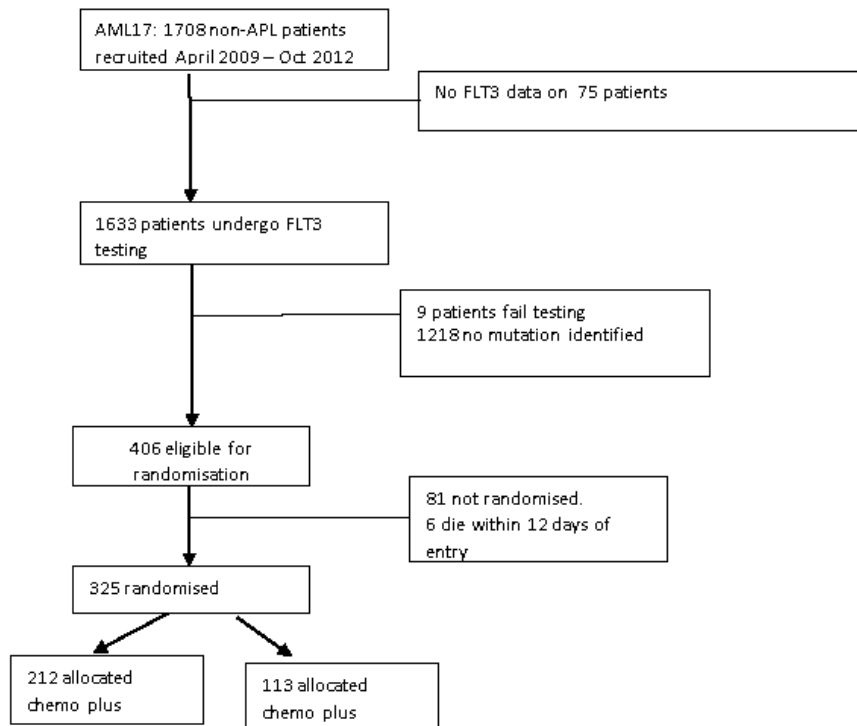
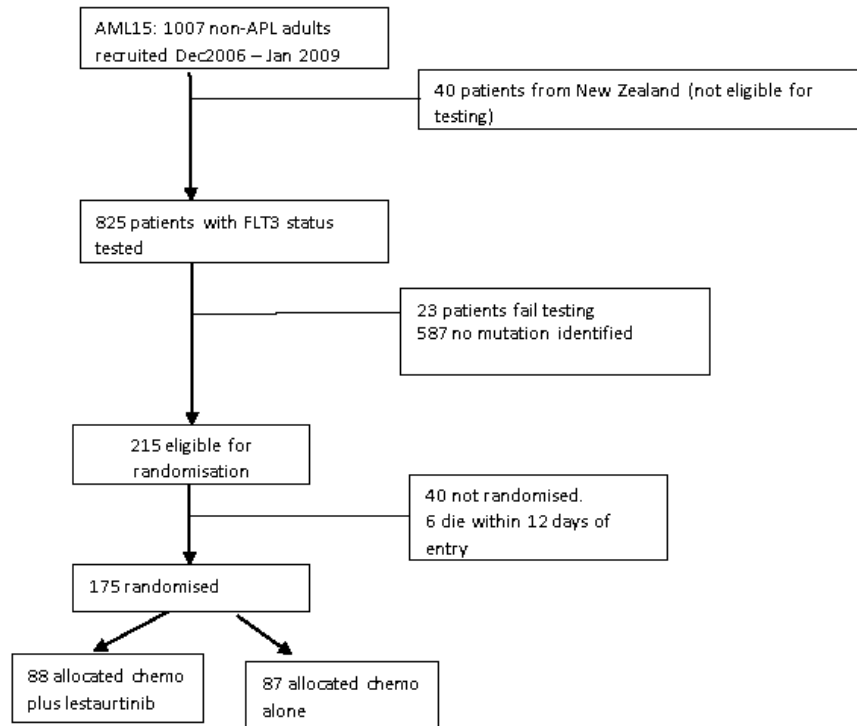
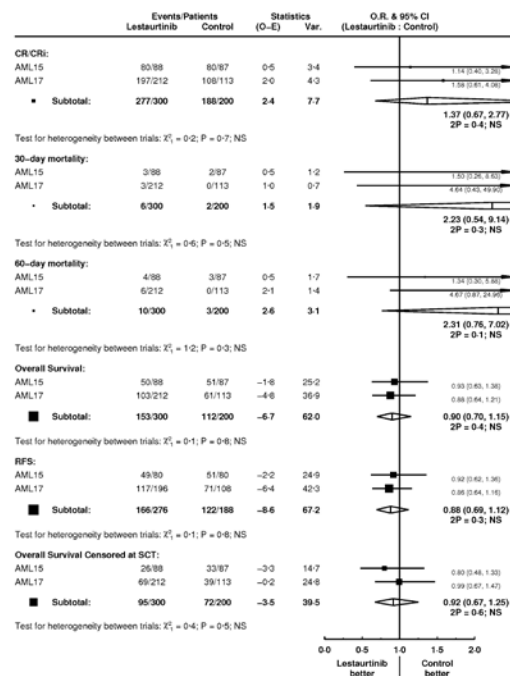
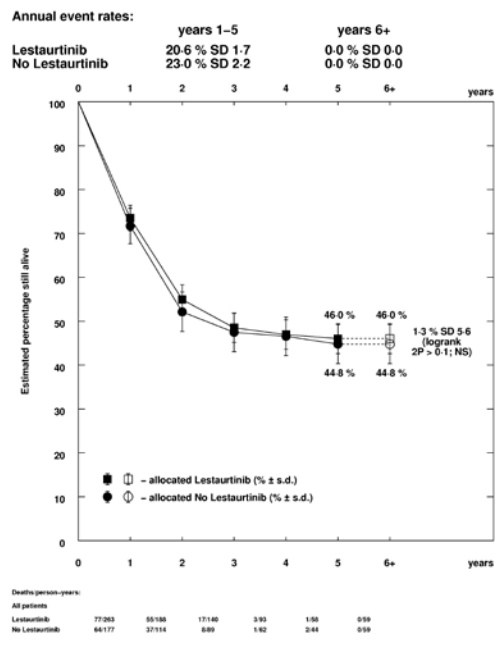

Figure 3: Outcomes by treatment. A) Forest plot stratified by trial; B) Overall Survival; C) Relapse Free Survival

A
AML15,17: Lestauritinib randomisation
Outcomes



B
AML15,17 Lestauritinib Randomisation
Overall Survival



C
AML15,17 Lestauritinib Randomisation
Relapse Free Survival

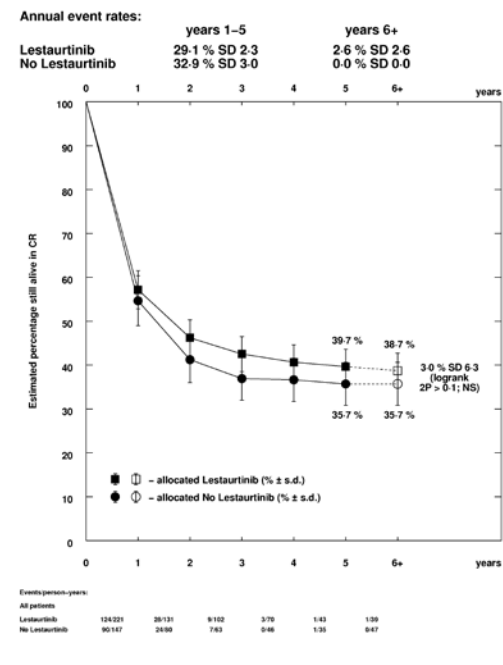

A)

Figure 4. Interaction with azole prophylaxis in AML17. A) Azole vs not; B) by type of azole; C) survival in patients given concomitant GO and azoles

A
AML17: Lestaurinib randomisation
by Azole treatment or not

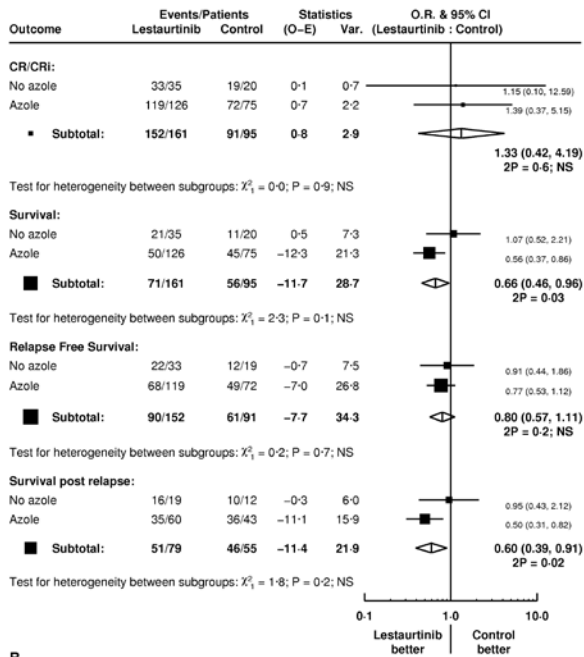

B
AML17: Lestaurinib randomisation
by Azole treatment or not
Overall Survival

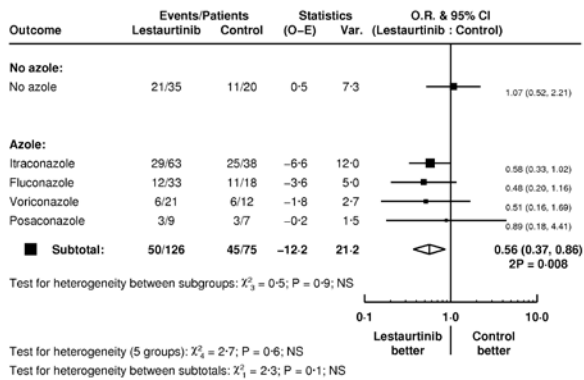

C
AML17: Survival by Lestaurinib
Concomitant GO and Azoles

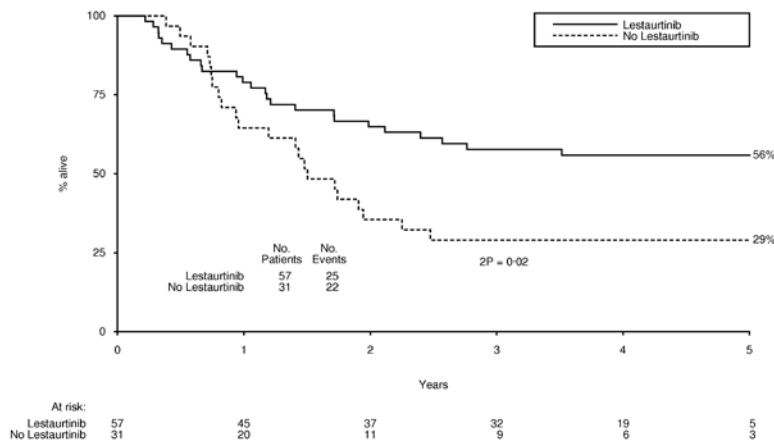

Figure 5: Analysis by Plasma Inhibition. A) Cumulative Incidence of Relapse; B) Overall Survival

